

Hydrostatic Speed Variator



 **TB Wood's**
Incorporated

An Altra Industrial Motion Company

HSV and HSV-A



HSV

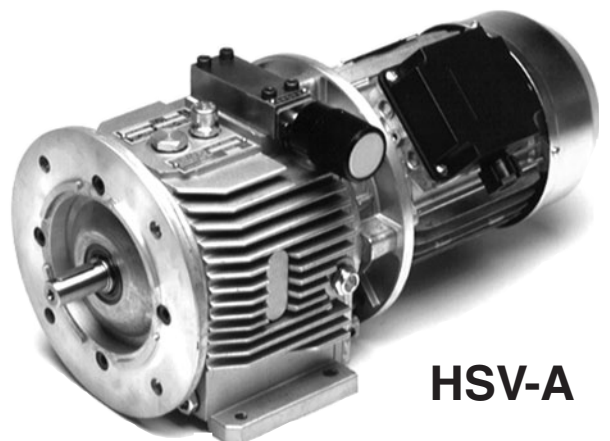

HSV-A

PRINCIPLE OF OPERATION

The Hydrostatic Speed Variator is an integrated hydrostatic transmission consisting of a variable displacement radial piston pump driving a fixed displacement radial piston motor. The pump-motor system is completely self-contained within one case providing light weight and ease of maintenance and serviceability.

The hydrostatic closed loop operates in the following manner. The input shaft (6) rotates the cylinder block of the radial piston pump (1). The pistons (13) stroke in and out of their cylinders pumping hydraulic oil through the distributor shaft (9) to the radial piston hydraulic motor (2). The oil then returns directly to the pump. In both the pump and the motor the stroke of the pistons is limited by the eccentric rings (7). The position of the pump eccentric ring is controlled by the regulating pin (8). This varies the flow rate from the pump to the motor. Since the motor eccentric ring is fixed in place, the speed of the hydraulic motor is directly proportional to the flow received from the pump. The pump eccentric ring can be moved to either side of the concentric center position thereby reversing the flow and reversing the output shaft. When a torque load is applied to the output shaft, a pressure which is proportional to the torque, is produced in the passages which transmit oil from the pump to the hydraulic motor. Some leakage occurs in these high pressure sections causing slip. The low pressure return line is supplied by a small charge pump (3). It makes up for the small leakage and maintains a positive pressure (approximately 120 psi) at the inlet of the main pump. The charge pump also provides positive lubrication and power to the hydraulic controls. The crossover check valves (5) direct the charge flow to the low pressure side of the closed loop. High system pressure is limited by the main relief valves (11). These provide protection from excessive torque overloads for both the variator and the driven machine.

The input and output shafts are independently mounted in their end covers and coupled to their respective cylinder blocks. Consequently, no shaft deflections are transmitted to the hydraulic mechanism and no hydraulic forces are carried by the shaft bearings.

The simplicity of concept and design make the HSV unique among variable speed drives.

Hydraulic Schematic

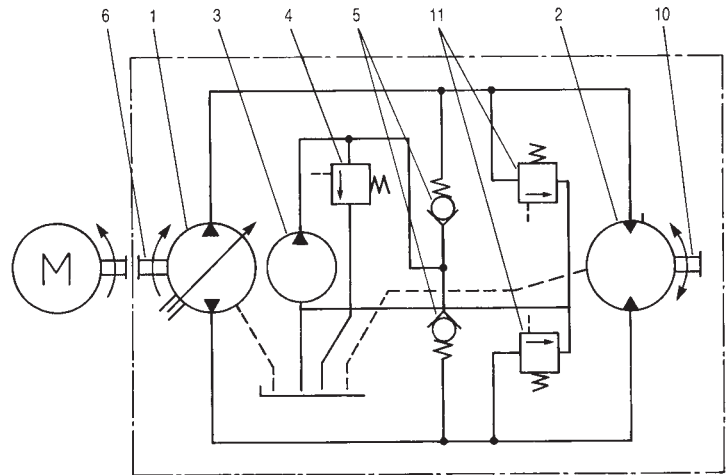

Legend

- | | |
|------------------------|--------------------------|
| 1. Radial Piston Pump | 8. Regulating Pin |
| 2. Radial Piston Motor | 9. Distributor Shaft |
| 3. Charge Pump | 10. Output Shaft |
| 4. Charge Relief Valve | 11. Safety Relief Valves |
| 5. Check Valves | 12. Case |
| 6. Input Shaft | 13. Pistons |
| 7. Eccentric Ring | |

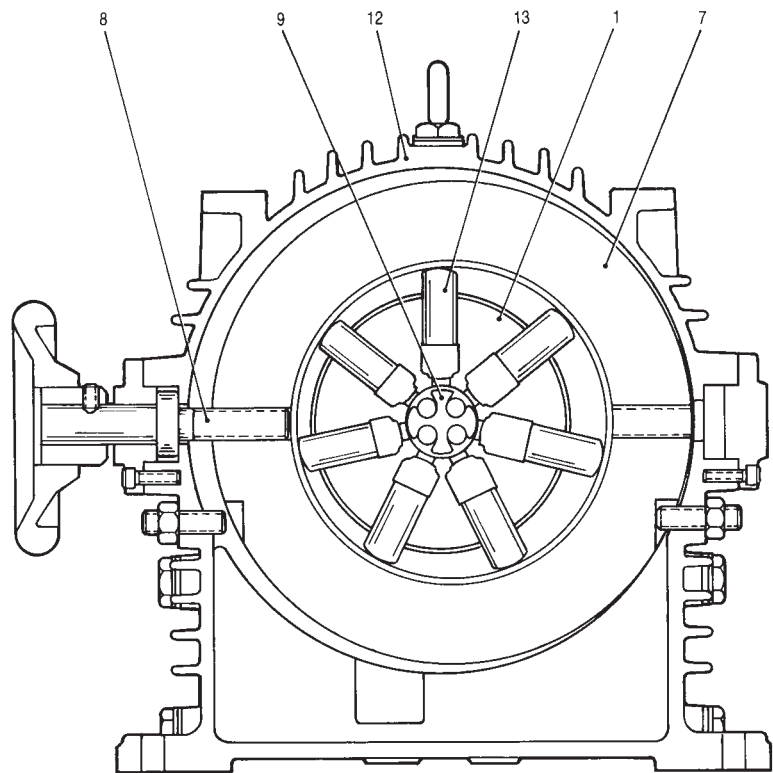

Input End
(Hydraulic Pump)

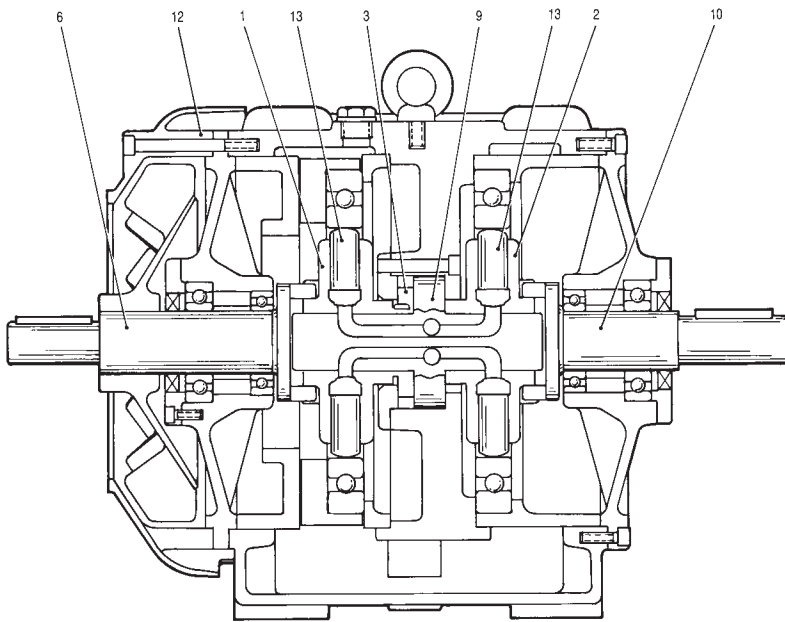
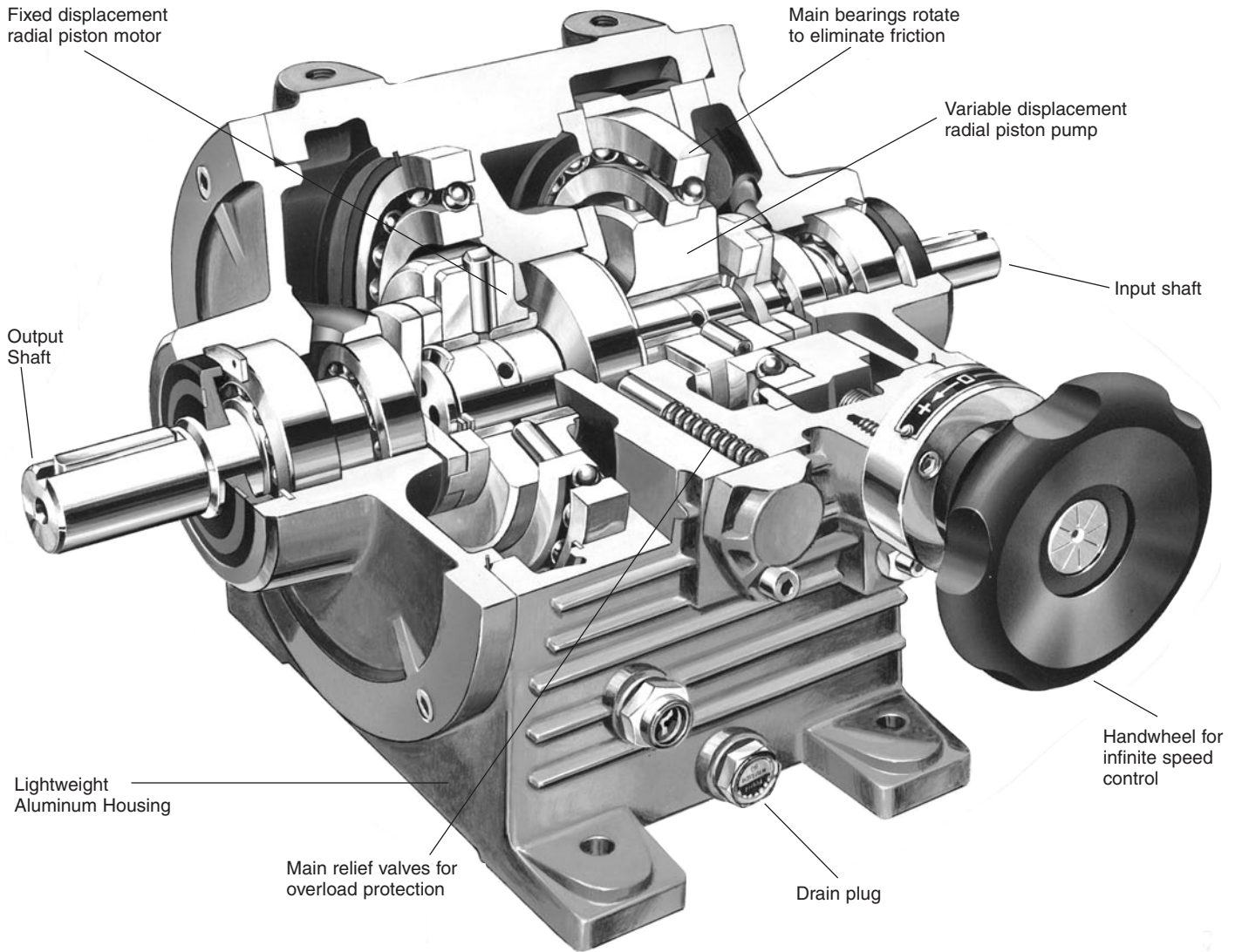

Size 15

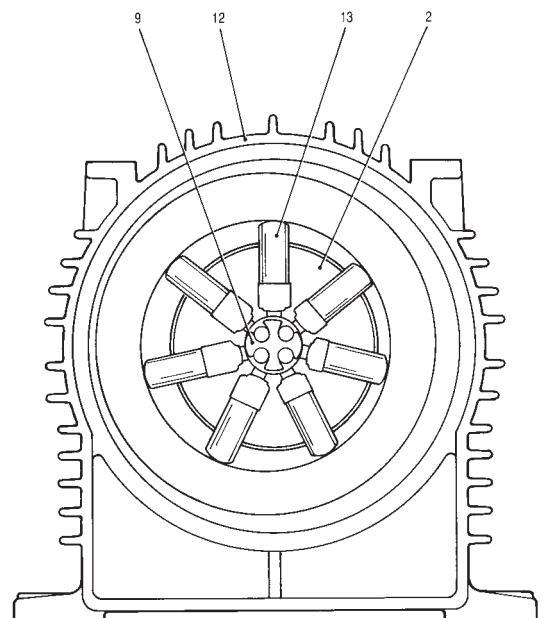

Output End (Hydraulic Motor)



Winding

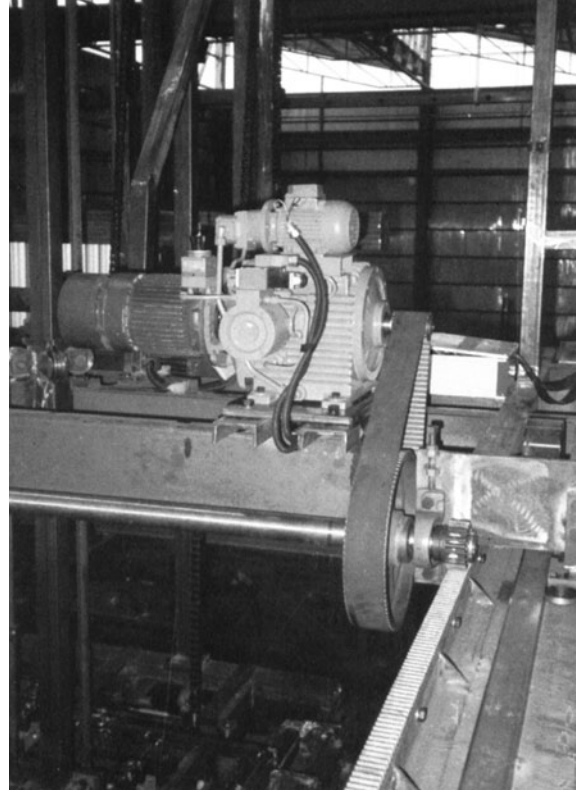

Materials Handling

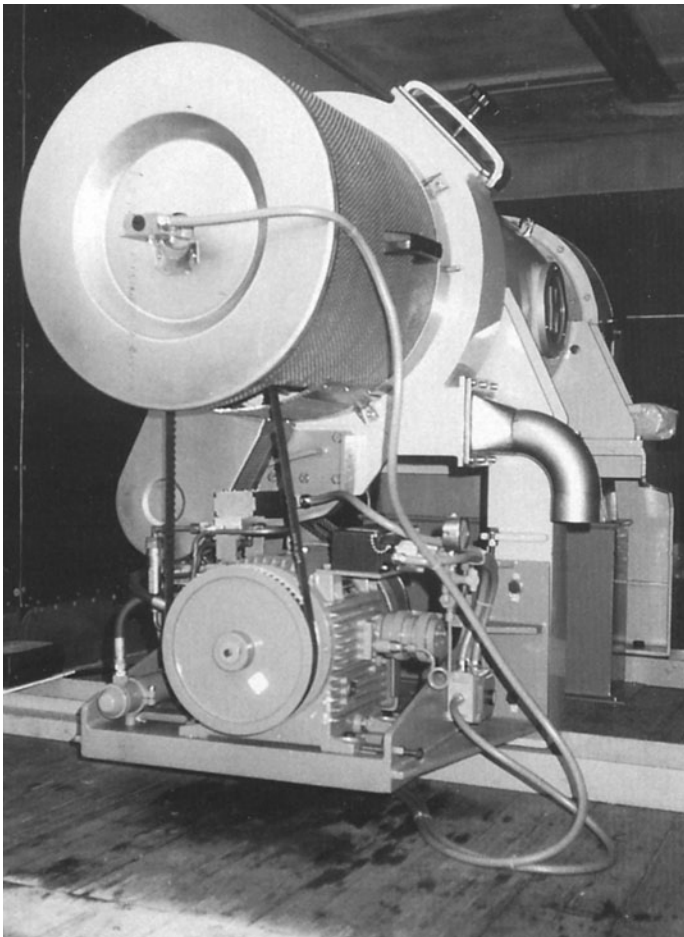

Centrifuge

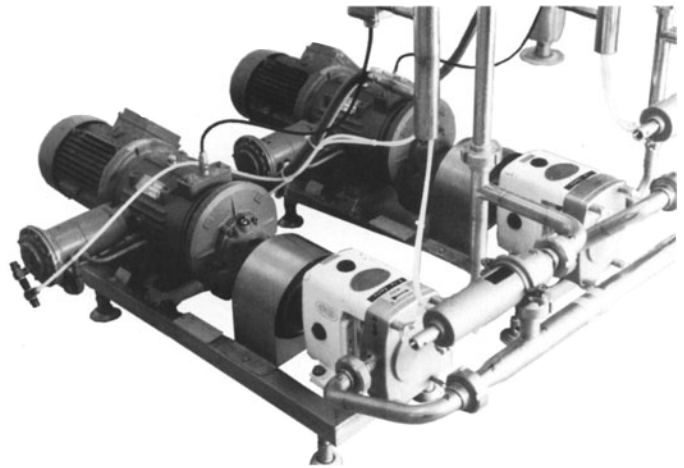

Pumping

HSV versus HSV-A Overview



HSV

Feature Comparison

	HSV	HSV-A
Output HP Range	1/2 to 20	1/3 to 4
Relative Cost	Higher	Lower
Housing Material	Cast Iron	Aluminum
Internal Gearing	Not Available	Optional

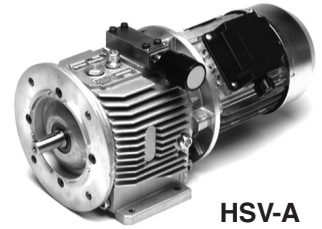

HSV-A

Input Options

	HSV	HSV-A
Shaft (T 10)	Std	Opt
NEMA C	Opt	Std
Top Mount Motor	Opt	NA

Output Options

	HSV	HSV-A
Shaft (T 10)	Std	Opt
NEMA C	Opt	Std

Manual Controls

	HSV	HSV-A
00 - Handwheel	Std	Std
01 - Right Angle HW	Opt	Opt
02 - Lever	Opt	Opt
03 - HD Lever	Opt	NA
09 - Flexible Shaft	Opt	NA
12 - Clevis	Opt	NA

Remote Controls

	HSV	HSV-A
20 - Electric (Fast)	Opt	Opt
22 - Electric (Slow)	Opt	Opt
23 - Electric (Very Slow)	Opt	Opt
31 - Hydraulic for PLC	NA	Opt
37 - Electro-Hydraulic	Opt	Opt
38 - Electro-Hydraulic	Opt	Opt
46 - HW w/ ramp start	Opt	Opt
49 - Electric w/ ramp start	Opt	Opt
52 - Hydraulic-Pneumatic	Opt	Opt
53 - Hydraulic-Pneumatic	Opt	NA
65 - Elect-Hydra w/ ps & 0	Opt	Opt
66 - Elect-Hydra w/ presets	Opt	Opt
67 - Electro-Hydraulic	Opt	Opt
68 - Electro-Hydraulic	Opt	NA
71 - Synchronized	NA	Opt
00/3 - Auto Winder	NA	Opt

Accessories

	HSV	HSV-A
0 - Dial Indicator HW	Opt	Opt
3 - Press Compensator	Opt	NA
4 - Adj. Tor. Limit Valve	Opt	NA
6 - Zero Dev. for Man Cont	Opt	NA
8A - Tach PU w/ Analog M	Opt	Opt
8D - Tach PU w/ Digital M	Opt	Opt
8L - Tach PU w/o Meter	Opt	Opt
9(2) - L Switch Box for RC	Opt	Opt
9(3) - L Switch Box for RC	Opt	Opt
9(6) - L Switch Box for RC	Opt	Opt

Options

	HSV	HSV-A
A - Separate Charge Pump	Opt	NA
B - Bypass Valve	Opt	NA
C - Vertical Mount	Opt	Opt
D - Reversible Charge Pump	Opt	Opt
F - Flow Control	Opt	NA
G - Potentiometer Feedback	Opt	Opt
M - Pressure Tap	Opt	Opt
M(G) - Press Tap w/ Gauge	Opt	Opt
M(PS) - Press Tap w/ Switch	Opt	NA
N - High Temp, Cutoff	Opt	Opt
P - Oil Preheat Kit	Opt	Opt
Q - Compensated Oil Flow	Opt	NA
R - External Cooler Valve	Opt	Opt
RR - Valve & Radiator	Opt	Opt
S - Electronic Adjuster (ERC)	Opt	Opt
W- Remote Speed Set	Opt	NA
Z(1) - Press Act. Breather	Opt	Opt
Z(2) - Epoxy Paint	Opt	Opt
Z(3) - Synthetic Oil	Opt	Opt

HSV 11

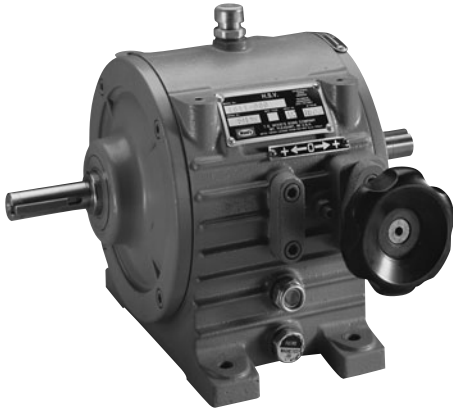

0.45 HP @ max. output speed with 1/2 HP electric motor

Max. Output Speed (RPM)	Running Torque (lb/ft)	Gearbox ratio/model	Weight (lbs)	
			w/motor	w/o motor
1700	1.4	—	48	23
833	2.9	2.04 DC11*	85	60
732	3.3	2.32 DC11*	85	60
600	4.0	2.83 DC11*	85	60
535	4.5	3.18 DC11*	85	60
472	5.0	3.60 DC11*	85	60
437	5.5	3.89 DC02	92	67
353	6.8	4.82 DC02	92	67
306	7.8	5.56 DC02	92	67
247	9.7	6.89 DC02	92	67
218	11.0	7.80 DC02	92	67
208	11.5	8.19 DC02	92	67
183	13.0	9.28 DC02	92	67
171	14.0	9.95 DC02	92	67
151	16	11.27 DC02	92	67
133	18	12.82 DC02	92	67
107	22	15.95 DC02	92	67
82	29	20.59 DC02	92	67
70	34	24.39 DC02	92	67
66	36	25.92 DC12	96	71
54	44	31.19 DC12	96	71
44	54	38.31 DC12	96	71
36	67	47.87 DC12	96	71
27	91	64.80 DC23*	134	109
22	109	78.05 DC23*	134	109
20	124	88.46 DC23*	134	109

Other gearbox ratios available.

*NOTE: Denotes single, triple, or quadruple reduction which reverses the output shaft rotation. If single rotation control is used, check for proper installation.

A2

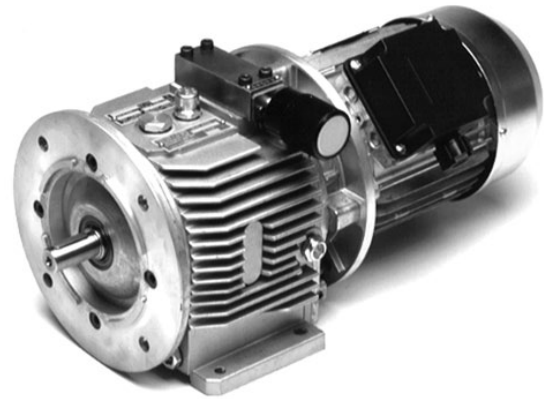

56C Input & Output Std.

.33 HP @ max output speed with 1/2 HP electric motor

Max. Speed (RPM)	Running Torque (ft. lbs.)	Gearbox ratio/model	Weight (lbs)	
			w/motor	w/o motor
1650	1.0	—	41	16
809	2.0	2.04 DC11*	78	53
711	2.3	2.32 DC11*	78	53
583	2.8	2.83 DC11*	78	53
519	3.2	3.18 DC11*	78	53
458	3.6	3.60 DC11*	78	53
424	3.9	3.89 DC02	85	60
342	4.8	4.82 DC02	85	60
297	5.6	5.56 DC02	85	60
239	6.9	6.89 DC02	85	60
212	7.8	7.80 DC02	85	60
201	8.2	8.19 DC02	85	60
178	9.3	9.28 DC02	85	60
166	10.0	9.95 DC02	85	60
146	11.3	11.27 DC02	85	60
129	12.8	12.82 DC02	85	60
103	16.0	15.95 DC02	85	60
80	20.6	20.59 DC02	85	60
68	24.4	24.39 DC02	85	60
64	25.9	25.92 DC12	89	64
53	31.2	31.19 DC12	89	64
43	38.3	38.31 DC12	89	64
34	47.9	47.87 DC12	89	64
25	64.8	64.80 DC23*	127	102
21	78.1	78.05 DC23*	127	102
19	88.5	88.46 DC23*	127	102

HSV 12



0.85 HP @ max. output speed with 1 HP electric motor

Max. Output Speed (RPM)	Running Torque (lb/ft)	Gearbox ratio/model	Weight (lbs)	
			w/motor	w/o motor
1700	2.6	—	65	29
834	5.4	2.04 DC11*	100	64
733	6.1	2.32 DC11*	100	64
601	7.4	2.83 DC11*	100	64
535	8.4	3.18 DC11*	100	64
473	9.5	3.60 DC11*	100	64
437	10.2	3.89 DC02	110	73
353	12.7	4.82 DC02	110	73
306	14.6	5.56 DC02	110	73
247	18.0	6.89 DC02	110	73
218	21	7.80 DC02	110	73
208	22	8.19 DC02	110	73
184	24	9.28 DC02	110	73
171	26	9.95 DC02	110	73
151	30	11.27 DC02	110	73
133	34	12.82 DC02	110	73
127	35	13.39 DC12	114	77
102	44	16.73 DC12	114	77
91	50	18.79 DC12	114	77
80	56	21.28 DC12	114	77
72	62	23.74 DC22	139	102
59	76	28.80 DC22	139	102
49	91	34.69 DC22	139	102
40	112	42.82 DC22	139	102
37	121	46.25 DC32	154	119
30	151	57.53 DC32	154	119
20	231	88.18 DC33*	167	132

A4

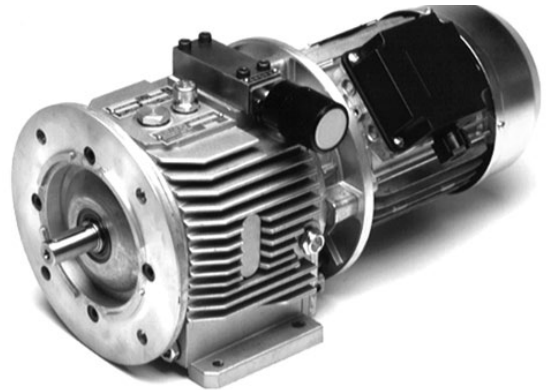

143TC Input & Output Std.

.75 HP @ max output speed with 1 HP electric motor

Max. Speed (RPM)	Running Torque (ft. lbs.)	Gearbox ratio/model	Weight (lbs)	
			w/motor	w/o motor
1650	2.1	—	60	24
809	4.3	2.04 DC11*	95	59
711	4.9	2.32 DC11*	95	59
583	5.9	2.83 DC11*	95	59
519	6.7	3.18 DC11*	95	59
458	7.6	3.60 DC11*	95	59
424	8.2	3.89 DC02	105	68
342	10.1	4.82 DC02	105	68
297	11.7	5.56 DC02	105	68
239	14.5	6.89 DC02	105	68
212	16.4	7.80 DC02	105	68
201	17.2	8.19 DC02	105	68
178	19.5	9.28 DC02	105	68
166	20.9	9.95 DC02	105	68
146	23.7	11.27 DC02	105	68
129	26.9	12.82 DC02	105	68
123	28.1	13.39 DC12	109	72
99	35.1	16.73 DC12	109	72
88	39.5	18.79 DC12	109	72
78	44.7	21.28 DC12	109	72
70	49.9	23.74 DC22	134	97
57	60.5	28.80 DC22	134	97
48	72.8	34.69 DC22	134	97
39	89.9	42.82 DC22	134	97
36	97.1	46.25 DC32	149	114
29	120.8	57.53 DC32	149	114
19	185.2	88.18 DC33*	162	127

Other gearbox ratios available.

*NOTE: Denotes single, triple, or quadruple reduction which reverses the output shaft rotation. If single rotation control is used, check for proper installation.

HSV 13

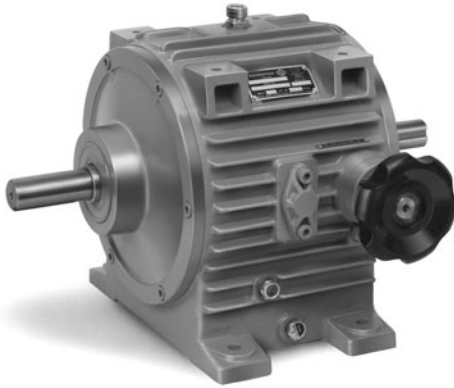

1.7 HP @ max. output speed with 2 HP electric motor

Max. Output Speed (RPM)	Running Torque (lb/ft)	Gearbox ratio/model	Weight (lbs)	
			w/motor	w/o motor
1700	5	—	105	60
834	11	2.04 DC11*	140	95
733	12	2.32 DC11*	140	95
600	15	2.83 DC11*	140	95
535	17	3.18 DC11*	140	95
473	19	3.60 DC11*	140	95
437	20	3.89 DC02	149	104
353	25	4.82 DC02	149	104
265	34	6.40 DC21*	151	106
260	35	6.53 DC12	153	108
216	41	7.85 DC12	153	108
176	51	9.65 DC12	153	108
158	56	10.70 DC12	153	108
126	70	13.39 DC12	153	108
115	77	14.69 DC22	178	133
101	88	16.75 DC22	178	133
71	125	23.74 DC22	178	133
68	130	24.73 DC22	178	133
59	151	28.8 DC22	178	133
54	164	31.16 DC32	195	150
51	174	33.05 DC32	195	150
45	195	37.23 DC32	195	150
36	243	46.25 DC32	195	150
29	302	57.53 DC32	195	150
24	368	70.12 DC43*	257	212
21	420	79.96 DC43*	257	212

A8

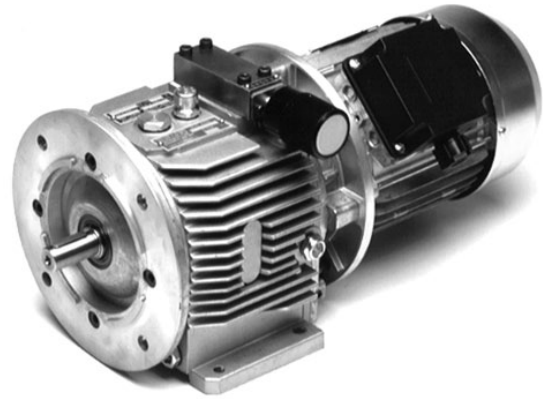

145TC Input & Output Std.
1.5 HP @ max output speed with 2 HP electric motor

Max. Speed (RPM)	Running Torque (ft. lbs.)	Gearbox ratio/model	Weight (lbs)	
			w/motor	w/o motor
1650	4.2	—	90	45
809	8.6	2.04 DC11*	125	80
711	9.7	2.32 DC11*	125	80
583	11.9	2.83 DC11*	125	80
519	13.4	3.18 DC11*	125	80
458	15.1	3.60 DC11*	125	80
424	16.3	3.89 DC02	134	89
342	20.2	4.82 DC02	134	89
258	26.9	6.40 DC21*	136	91
253	27.4	6.53 DC12	138	93
208	33.4	7.85 DC12	138	93
171	40.5	9.65 DC12	138	93
154	44.9	10.70 DC12	138	93
123	56.2	13.39 DC12	138	93
112	61.7	14.69 DC22	163	118
99	70.4	16.75 DC22	163	118
70	99.7	23.74 DC22	163	118
67	103.9	24.73 DC22	163	118
57	121.0	28.8 DC22	163	118
53	130.9	31.16 DC32	180	135
50	138.8	33.05 DC32	180	135
44	156.4	37.23 DC32	180	135
36	194.3	46.25 DC32	180	135
29	241.6	57.53 DC32	180	135
24	294.5	70.12 DC43*	242	197
21	335.8	79.96 DC43*	242	197

Other gearbox ratios available.

*NOTE: Denotes single, triple, or quadruple reduction which reverses the output shaft rotation. If single rotation control is used, check for proper installation.

HSV 14

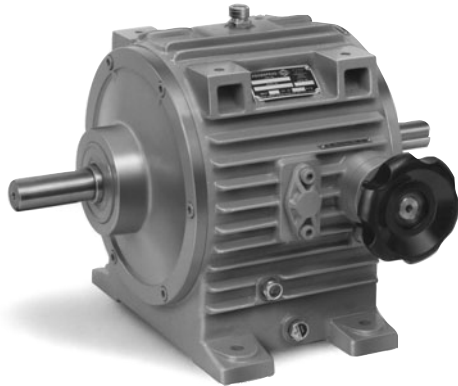

2.5 HP @ max. output speed with 3 HP electric motor

Max. Output Speed (RPM)	Running Torque (lb/ft)	Gearbox ratio/model	Weight (lbs)	
			w/motor	w/o motor
1700	8	—	134	71
817	16	2.08 DC21*	187	122
702	20	2.42 DC21*	187	122
550	26	3.09 DC21*	187	122
463	28	3.67 DC21*	187	122
328	40	5.18 DC22	213	148
293	45	5.79 DC22	213	148
261	50	6.51 DC22	213	148
224	58	7.57 DC22	213	148
200	65	8.48 DC22	213	148
156	84	10.89 DC22	213	148
139	94	12.20 DC22	213	148
115	113	14.69 DC22	213	148
82	160	20.70 DC32	231	166
64	205	26.57 DC32	231	166
54	241	31.16 DC32	231	166
48	282	35.25 DC42	279	214
29	450	58.27 DC53*	292	227
21	615	79.69 DC53*	325	260

Other gearbox ratios available.

*NOTE: Denotes single, triple, or quadruple reduction which reverses the output shaft rotation. If single rotation control is used, check for proper installation.

A10

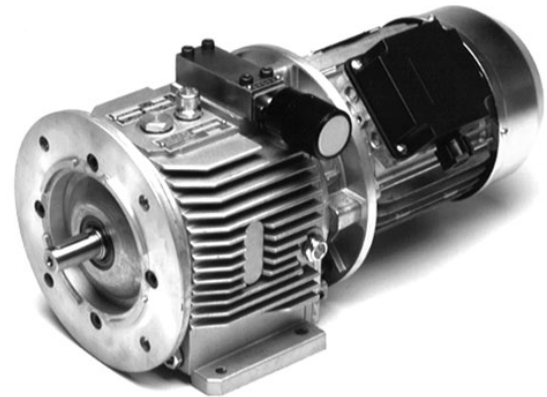

182TC Input & Output Std.

2.0 HP @ max output speed with 3 HP electric motor

Max. Speed (RPM)	Running Torque (ft. lbs.)	Gearbox ratio/model	Weight (lbs)	
			w/motor	w/o motor
1650	6.0	—	139	76
793	12.5	2.08 DC21*	192	127
682	14.5	2.42 DC21*	192	127
534	18.5	3.09 DC21*	192	127
450	22.0	3.67 DC21*	192	127
319	31.1	5.18 DC22	218	153
285	34.7	5.79 DC22	218	153
253	39.1	6.51 DC22	218	153
218	45.4	7.57 DC22	218	153
195	50.9	8.48 DC22	218	153
152	65.3	10.89 DC22	218	153
135	73.2	12.2 DC22	218	153
112	88.1	14.69 DC22	218	153
80	124.2	20.70 DC32	236	171
62	159.4	26.57 DC32	236	171
53	187.0	31.16 DC32	236	171
47	211.5	35.25 DC42	284	219
28	349.6	58.27 DC53*	297	232
22	460.1	79.69 DC53*	330	265

HSV 15

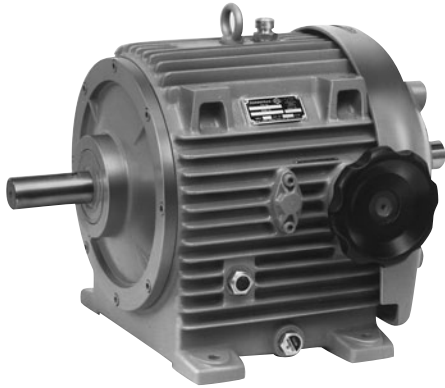

4 HP @ max. output speed with 5 HP electric motor

Max. Output Speed (RPM)	Running Torque (lb/ft)	Gearbox ratio/model	Weight (lbs)	
			w/motor	w/o motor
1700	12	—	215	132
817	26	2.08 DC21*	266	183
702	30	2.42 DC21*	266	183
627	33	2.71 DC21*	266	183
513	41	3.31 DC31*	281	198
463	45	3.67 DC31*	281	198
427	49	3.97 DC22	292	209
367	57	4.63 DC22	292	209
328	64	5.18 DC22	292	209
293	72	5.79 DC22	292	209
261	80	6.51 DC22	292	209
224	94	7.57 DC22	292	209
215	98	7.90 DC32	323	240
173	121	9.80 DC32	323	240
145	145	11.71 DC32	323	240
116	180	14.55 DC32	323	240
113	186	15.03 DC32	323	240
101	206	16.67 DC32	323	240
91	231	18.67 DC32	323	240
80	260	21.06 DC42	358	275
69	302	24.41 DC42	358	275
69	320	25.88 DC42	358	275
58	362	29.29 DC42	358	275
52	396	32.09 DC52	389	306
44	475	38.45 DC52	389	306
27	780	62.87 DC63*	514	431
22	950	77.46 DC63*	514	431

A12

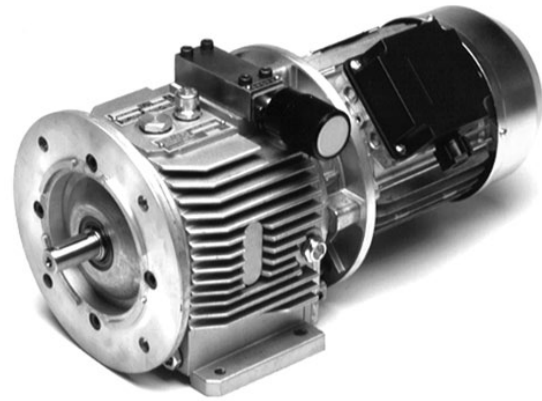

184TC Input & Output Std.

3.75 HP @ max output speed with 5 HP electric motor

Max. Speed (RPM)	Running Torque (ft. lbs.)	Gearbox ratio/model	Weight (lbs)	
			w/motor	w/o motor
1650	11.5	—	159	76
793	23.9	2.08 DC21*	210	127
682	27.8	2.42 DC21*	210	127
609	31.2	2.71 DC21*	210	127
498	38.1	3.31 DC31*	225	142
450	42.2	3.67 DC31*	225	142
416	45.7	3.97 DC22	236	153
356	53.2	4.63 DC22	236	153
319	59.6	5.18 DC22	236	153
285	66.6	5.79 DC22	236	153
253	74.9	6.51 DC22	236	153
218	87.1	7.57 DC22	236	153
209	90.9	7.90 DC32	267	184
168	112.7	9.80 DC32	267	184
141	134.7	11.71 DC32	267	184
113	167.3	14.55 DC32	267	184
110	172.8	15.03 DC32	267	184
99	191.7	16.67 DC32	267	184
88	214.7	18.67 DC32	267	184
78	242.2	21.06 DC42	302	219
68	280.7	24.41 DC42	302	219
64	297.6	25.88 DC42	302	219
56	336.8	29.29 DC42	302	219
51	369.0	32.09 DC52	333	250
43	442.2	38.45 DC52	333	250
26	723.0	62.87 DC63*	458	375
21	890.8	77.46 DC63*	458	375

Other gearbox ratios available.

*NOTE: Denotes single, triple, or quadruple reduction which reverses the output shaft rotation. If single rotation control is used, check for proper installation.

HSV 16

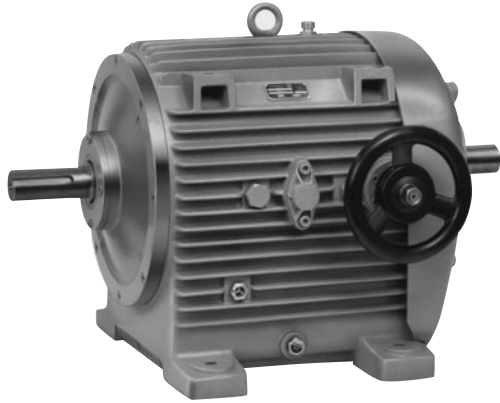

7.6 HP @ max. output speed with 10 HP electric motor

Max. Output Speed (RPM)	Running Torque (lb/ft)	Gearbox ratio/model	Weight (lbs)	
			w/motor	w/o motor
1700	23	—	431	286
817	48	2.08 DC31*	510	365
659	59	2.58 DC31*	510	365
552	71	3.08 DC41*	561	416
384	102	4.43 DC32	539	394
309	127	5.50 DC32	539	394
252	155	6.74 DC32	539	394
215	182	7.90 DC32	539	394
173	225	9.80 DC32	539	394
138	282	12.28 DC42	605	460
112	348	15.12 DC42	605	460
99	394	17.15 DC52	636	491
73	535	23.27 DC52	636	491
46	852	37.05 DC62	785	640
35	1121	48.73 DC62	785	640
34	1167	50.73 DC63	761	616
32	1238	53.82 DC63	761	616
27	1446	62.87 DC63	761	616
23	1722	74.87 DC73*	884	739

HSV 16B

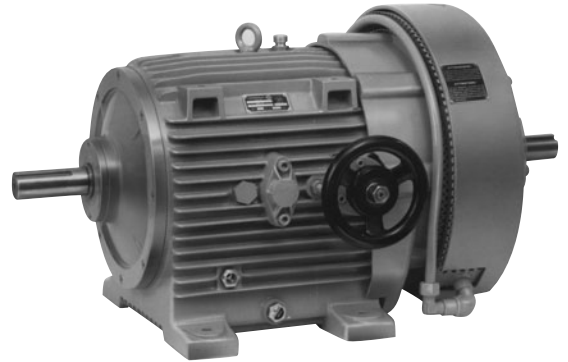

12 HP @ max output speed with 15 HP electric motor

Max. Speed (RPM)	Running Torque (ft. lbs.)	Gearbox ratio/model	Weight (lbs)	
			w/motor	w/o motor
1500	44	—	612	330
721	92	2.08 DC31*	691	409
581	114	2.58 DC31*	691	409
487	136	3.08 DC41*	704	422
453	146	3.31 DC51*	759	477
371	178	4.04 DC51*	759	477
327	202	4.58 DC42	786	504
280	235	5.35 DC42	786	504
242	272	6.19 DC42	786	504
206	320	7.28 DC42	786	504
176	374	8.50 DC42	786	504
147	449	10.2 DC42	786	504
123	532	12.10 DC52	817	535
107	616	14.00 DC52	817	535
87	755	17.15 DC52	817	535
82	800	18.14 DC62	966	684
40	1630	37.05 DC62	966	684
34	1900	43.11 DC72	1089	807
28	2300	52.24 DC73*	1065	783
25	2660	60.46 DC73*	1065	783
24	2720	61.89 DC83*	1281	999
21	3090	70.24 DC83*	1281	999

Other gearbox ratios available.

*NOTE: Denotes single, triple, or quadruple reduction which reverses the output shaft rotation. If single rotation control is used, check for proper installation.

HSV 17

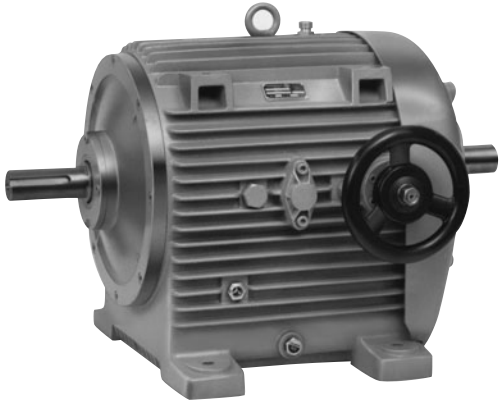

15 HP @ max. output speed with 20 HP electric motor

Max. Output Speed (RPM)	Running Torque (lb/ft)	Gearbox ratio/model	Weight (lbs)	
			w/motor	w/o motor
1400	53	—	790	484
307	239	4.56 DC62	1182	876
264	278	5.29 DC62	1182	876
220	333	6.35 DC62	1182	876
185	397	7.57 DC62	1182	876
159	461	8.78 DC62	1182	876
132	554	10.55 DC62	1182	876
120	608	11.59 DC62	1182	876
100	730	13.92 DC62	1182	876
88	830	15.80 DC62	1182	876
77	950	18.14 DC62	1182	876
64	1140	21.64 DC72	1306	1000
48	1500	28.63 DC72	1306	1000
34	2120	40.45 DC82	1531	1225
28	2560	48.82 DC82	1531	1225
25	2910	55.51 DC83*	1496	1190
22	3250	61.89 DC83*	1496	1190
20	3690	70.24 DC83*	1496	1190

HSV 17B



21HP @ max output speed with 30 HP electric motor

Max. Speed (RPM)	Running Torque (ft. lbs.)	Gearbox ratio/model	Weight (lbs)	
			w/motor	w/o motor
1400	75	—	1002	540
307	340	4.56 DC62	1394	932
264	400	5.29 DC62	1394	932
220	480	6.35 DC62	1394	932
185	570	7.57 DC62	1394	932
159	660	8.78 DC62	1394	932
132	790	10.55 DC62	1394	932
120	870	11.59 DC62	1394	932
100	1040	13.92 DC62	1394	932
88	1190	15.80 DC62	1394	932
77	1360	18.14 DC62	1394	932
64	1620	21.64 DC72	1517	1055
48	2150	28.63 DC72	1517	1055
42	2490	33.24 DC73	1493	1031
35	2930	39.08 DC83*	1708	1246
31	3330	44.38 DC83*	1708	1246
26	4040	53.80 DC93*	2007	1545
22	4620	61.63 DC93*	2007	1545
19	5440	72.47 DC93*	2007	1545

Other gearbox ratios available.

*NOTE: Denotes single, triple, or quadruple reduction which reverses the output shaft rotation. If single rotation control is used, check for proper installation.

HSV PERFORMANCE DATA



Performance Factors

- Intermittent torque is the torque to which the HSV can be loaded without overloading the electric motor. Momentary torque overloads up to the starting torque can be tolerated by the HSV.
- Continuous torque is the torque not to be exceeded under continuous operation.
- Minimum output speed at continuous torque is 50 RPM for all sizes. This results in the speed ratios as shown in the table below. It is possible to run somewhat below 50 RPM at reduced torque load.

Speed Ratios

RPM Input	Speed Ratio Available
1750	42:1
1450	36:1
1140	27:1

- Minimum input speed is 500 RPM to ensure sufficient charge flow. Lower input speeds can be accommodated by utilizing a separate charge pump, Option Code A.

Service Factors

The following Service Factors should be applied when selecting the HSV size.

Duty C₁

Running Hours Per Day	Service Factor C ₁
8	1
8-15	1.1
15-24	1.2

Cycling Loading C₂

Cycle Rate	Service Factor C ₂
Low	0
Medium (60 per hr)	0.1
High (10 per minute)	0.3
Very High (30 per minute)	Consult Factory

Temperature C₃

Ambient Temperature	Service Factor C ₃
Up to 80° F	0
From 85° F to 105° F	0.4
Higher than 105° F	Consult Factory

Service Factor is the sum of C₁, C₂, and C₃

$$S.F. = C_1 + C_2 + C_3$$

Power and Torque Performance at Output Shaft

HSV 11 With 1/2 HP Motor Starting Torque 5 ft. lbs.

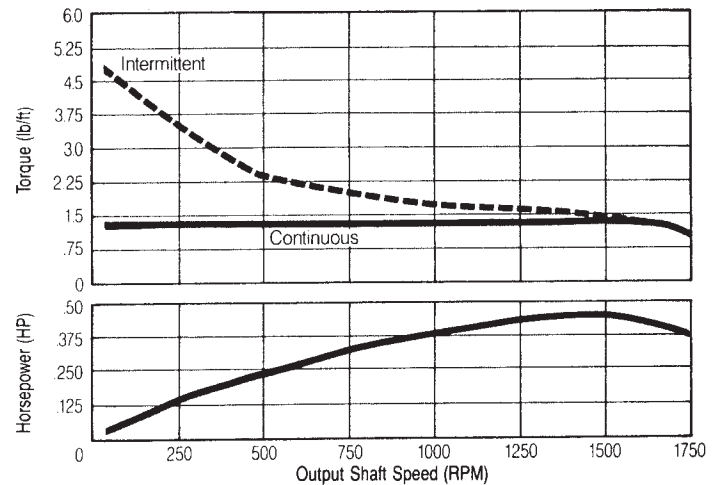

HSV 12 With 1 HP Motor Starting Torque 10 ft. lbs.

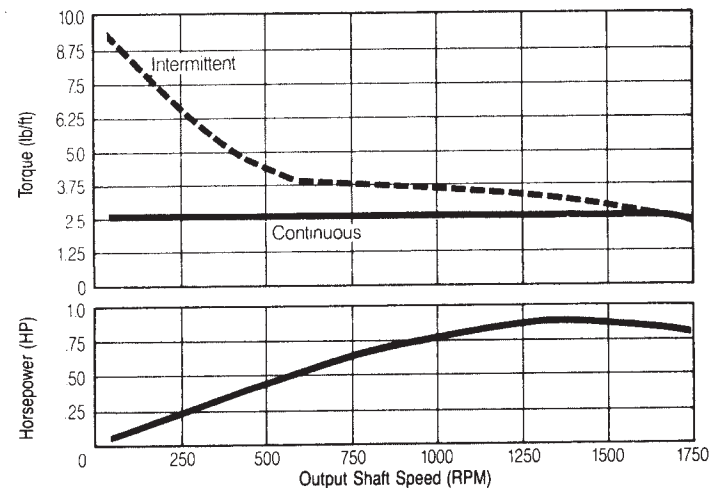

HSV 13 With 2 HP Motor Starting Torque 18 ft. lbs.

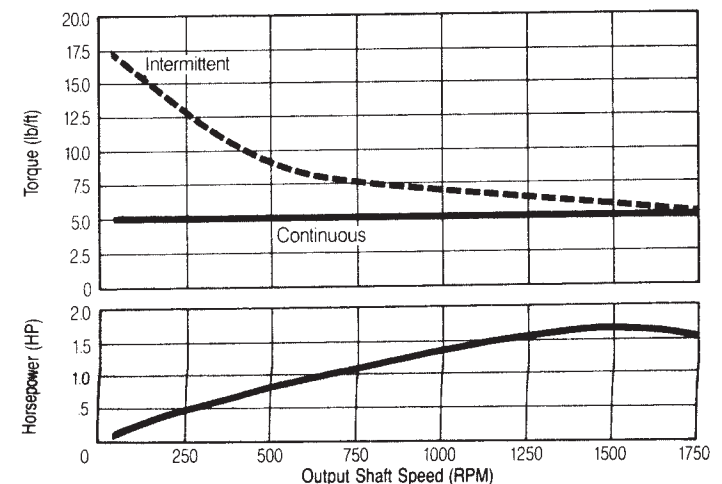



HSV PERFORMANCE DATA

HSV 14 With 3 HP Motor Starting Torque 25 ft. lbs.

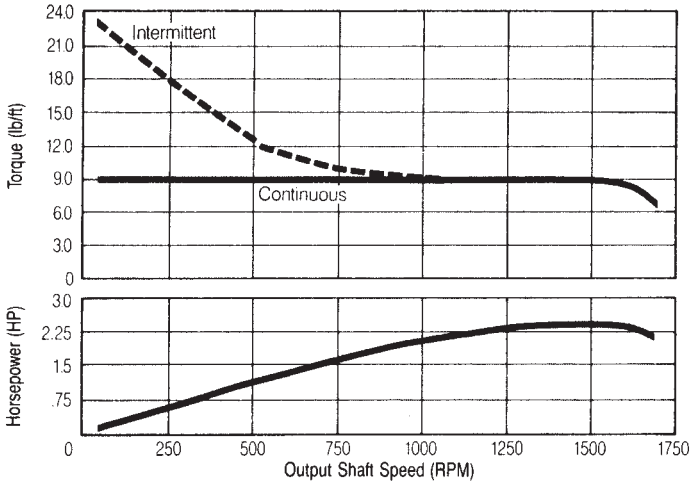

HSV 16B With 15 HP Motor Starting Torque 75 ft. lbs.

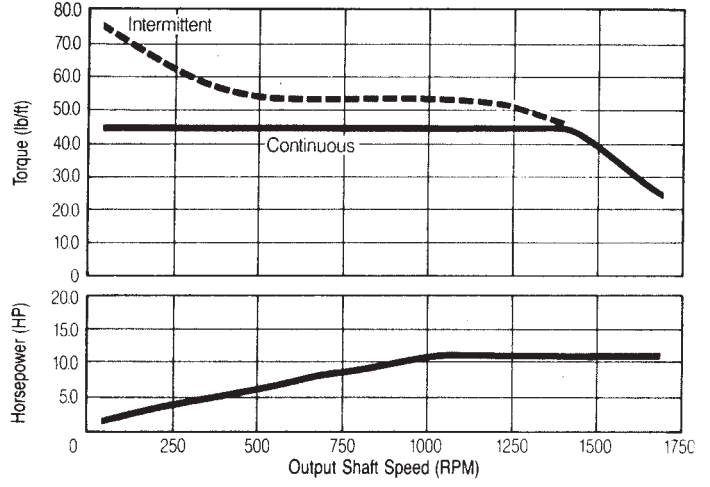

HSV 15 With 5 HP Motor Starting Torque 40 ft. lbs.

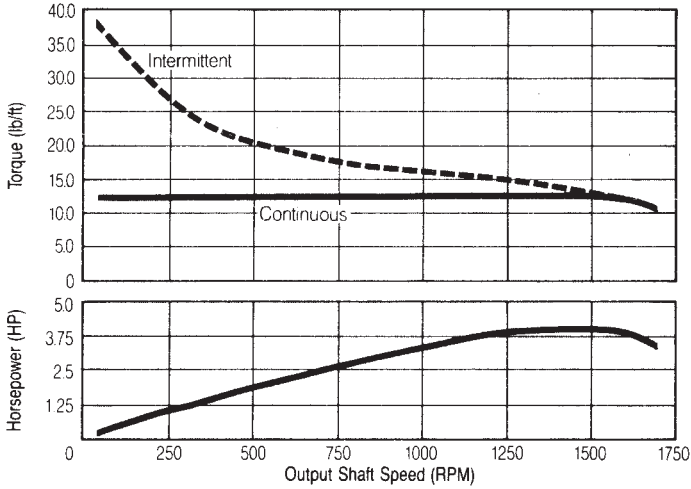

HSV 17 With 20 HP Motor Starting Torque 130 ft. lbs.

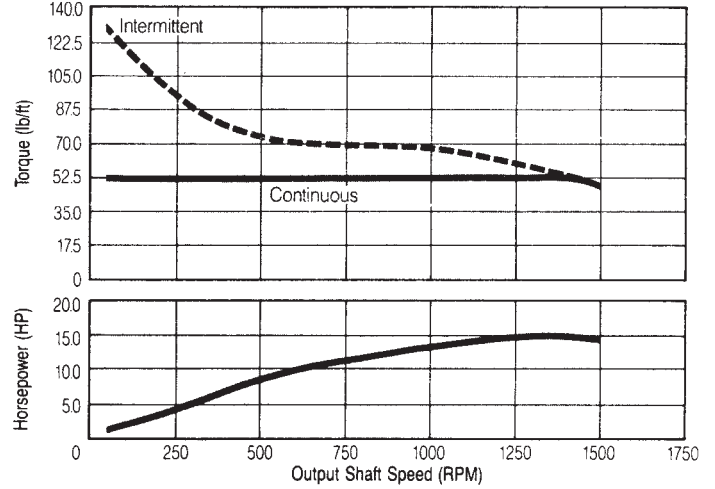

HSV 16 With 10 HP Motor Starting Torque 65 ft. lbs.

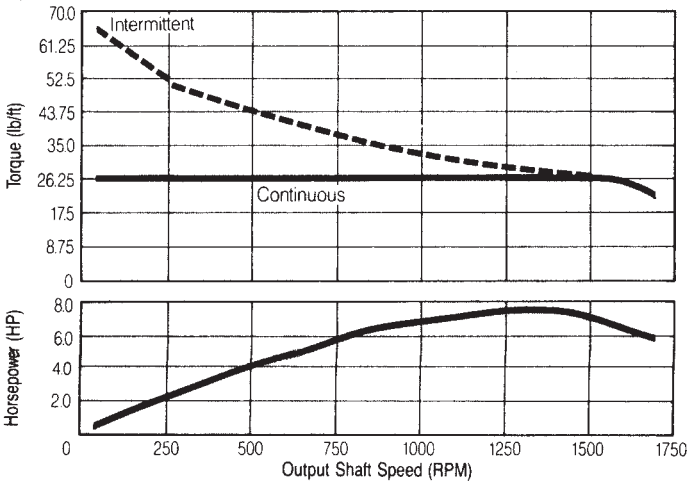

HSV 17B With 30 HP Motor Starting Torque 180 ft. lbs.

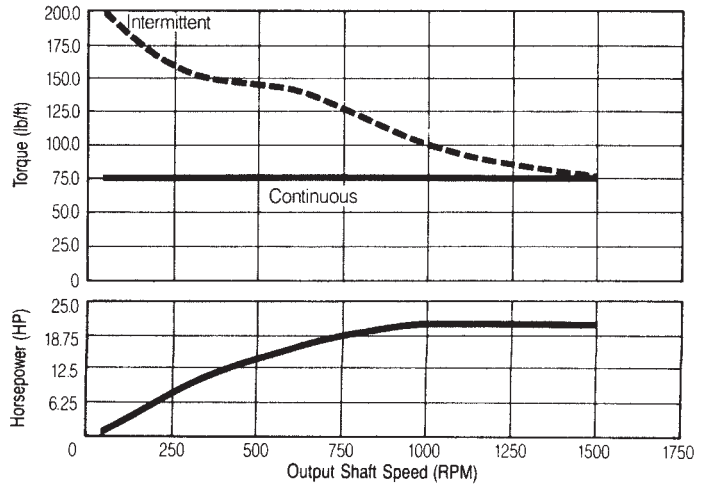

HSV-A PERFORMANCE DATA



Standard HSV-A UNIT

INPUT		Model	OUTPUT				
HP	RPM		RPM Range	Stable RPM	HP@ Max.	Running TQ (ft. lb.)	Start TQ (ft. lb.)
1/2	1750	A2	1750-0	50	0.35	1.0	4.8
1/3	1140	A2	1140-0	40	0.25	1.2	4.8
1	1750	A4	1750-0	50	0.72	2.2	9.2
3/4	1140	A4	1140-0	40	0.56	2.6	9.2
2	1750	A8	1750-0	50	1.44	4.3	17.0
1 1/2	1140	A8	1140-0	40	1.12	5.1	17.0
3	1750	A10	1750-0	50	2.06	6.0	36.9
2	1140	A10	1140-0	40	1.30	5.8	36.9
5	1750	A12	1750-0	50	3.44	10.3	36.9
3	1140	A12	1140-0	40	2.10	9.1	36.9

HSV-A/X UNIT (Internal Gear Reduction)

INPUT		Model	OUTPUT				
HP	RPM		RPM Range	Stable RPM	HP@ Max.	Running TQ (ft.lb.)	Start TQ (ft.lb.)
1/2	1750	A2/X	1120-0	50	0.35	1.6	4.8
1/3	1140	A2/X	730-0	40	0.25	1.8	4.8
1	1750	A4/X	1175-0	50	0.72	3.2	9.4
3/4	1140	A4/X	765-0	40	0.56	3.8	9.4
2	1750	A8/X	1315-0	50	1.44	5.7	17.1
1 1/2	1140	A8/X	860-0	40	1.12	6.7	17.1
3	1750	A10/X	1340-0	50	2.06	8.0	53.5
2	1140	A10/X	875-0	40	1.30	7.7	53.5
5	1750	A12/X	1340-0	50	3.44	13.3	53.5
3	1140	A12/X	875-0	40	2.10	12.4	53.5

HSV-A/Y UNIT (Internal Gear Increase)

INPUT		Model	OUTPUT				
HP	RPM		RPM Range	Stable RPM	HP@ Max.	Running TQ (ft.lb.)	Start TQ (ft.lb.)
1/2	1750	A2/Y	2735-0	50	0.35	0.7	4.8
1/3	1140	A2/Y	1780-0	40	0.25	0.7	4.8
1	1750	A4/Y	2615-0	50	0.72	1.4	9.2
3/4	1140	A4/Y	1705-0	40	0.56	1.7	9.2
2	1750	A8/Y	2330-0	50	1.44	3.2	16.9
1 1/2	1140	A8/Y	1520-0	40	1.12	3.8	16.9
3	1750	A10/Y	2290-0	50	2.06	4.7	25.8
2	1140	A10/Y	1490-0	40	1.30	4.5	25.8
5	1750	A12N	2290-0	50	3.44	7.8	25.8
3	1140	A12N	1490-0	40	2.10	7.3	25.8



DIMENSIONS - HSV HYDROSTATIC SPEED VARIATORS

Type 10 Standard Units

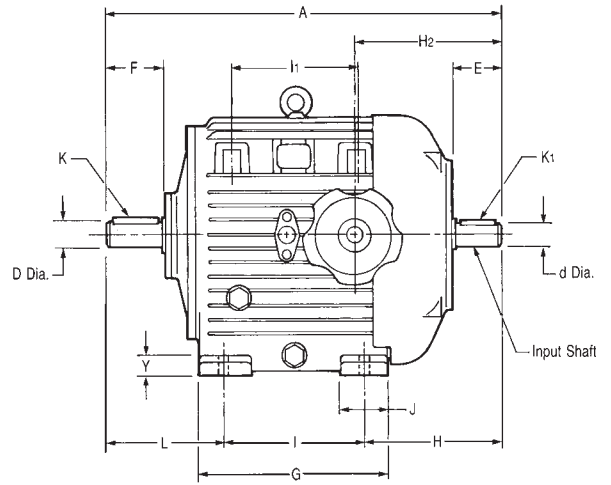
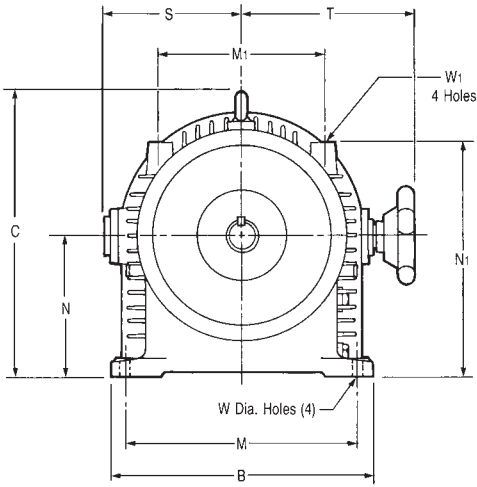

Type 11 NEMA C-flange Input and Output

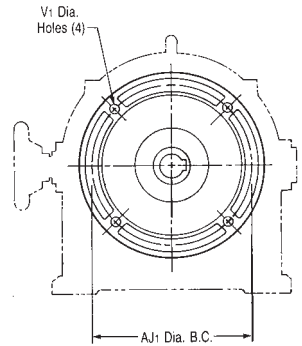
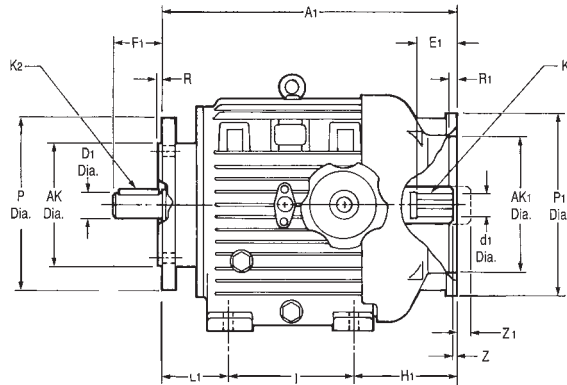
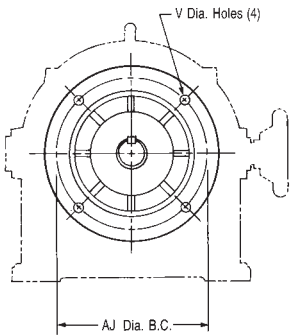

NEMA Frame Size/ Unit Weights

HSV Size	Input	Output	Wt. (lbs.)
11	56C	56C	23
12	143TC	143TC	29
13	145TC	145TC	60
14	182TC	182TC	71
15	184TC	184TC	132
16	215TC	215TC	288
16B	—	215TC	330
17	—	284TC	484
17B	—	284TC	540

Type 21 Motor Variator with NEMA C-flange motor on input

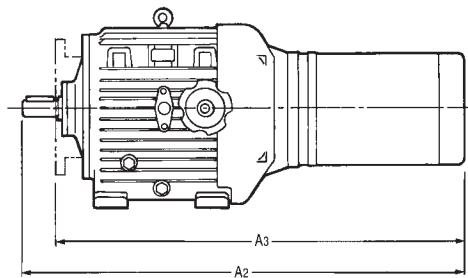

Type 22 Motor Variator with top- mounted motor

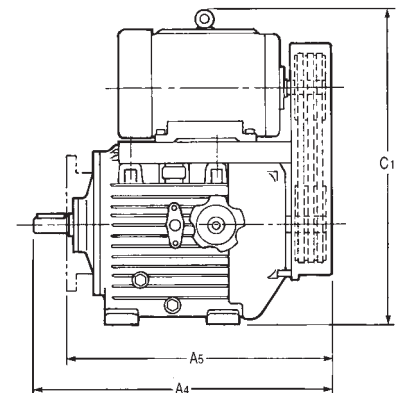

DIMENSIONS – HSV HYDROSTATIC SPEED VARIATORS



HSV Size	A	A ₁	B	C	d	d ₁	D	D ₁	E	E ₁	F	F ₁	G	H	H ₁	H ₂	I	I ₁	J	K	K ₁	K ₂
11	10.03	8.46	7.09	7.24	.625	.625	.875	.625	1.188	2.99	1.750	1.75	4.37	3.16	3.09	3.0	3.15	3.54	1.18	.188	.188	.188
12	12.70	9.87	7.87	7.95	.875	.875	.875	.875	1.625	3.17	2.250	2.12	5.31	4.07	3.31	4.2	3.94	3.54	1.38	.188	.188	.188
13	15.03	11.07	10.63	10.16	.875	.875	.875	.875	2.000	3.05	2.250	2.12	6.81	4.97	3.33	5.0	4.84	4.65	1.97	.188	.188	.188
14	16.49	12.20	11.18	10.94	1.125	1.125	1.125	1.125	2.000	3.36	2.750	2.88	7.09	5.31	3.84	5.4	5.12	4.92	1.97	.250	.250	.250
15	20.64	17.22	13.54	14.53	1.375	1.125	1.375	1.125	2.375	2.95	3.375	2.88	9.45	7.06	6.93	7.7	7.09	6.30	2.36	.312	.312	.250
16	26.85	23.14	16.54	16.93	1.625	1.375	1.625	1.375	3.125	4.25	4.000	3.38	12.20	9.01	8.96	9.5	9.25	7.87	2.95	.375	.375	.312
16B	33.82	—	16.54	17.72	1.625	—	1.625	1.375	4.250	—	4.000	3.38	12.20	15.98	—	16.5	9.25	7.87	2.95	.375	.375	.312
17	31.23	—	19.69	21.10	1.875	—	1.875	1.875	4.250	—	4.525	4.62	15.16	10.31	—	11.31	11.61	9.72	3.54	.500	.500	.500
17B	37.36	—	19.69	21.10	1.875	—	1.875	1.875	4.250	—	4.525	4.62	15.16	16.44	—	17.2	11.61	9.72	3.54	.500	.500	.500

HSV Size	K ₃	L	L ₁	M	M ₁	N	N ₁	P	P ₁	R	R ₁	S	T	V	V ₁	W	W ₁	Y	Z	Z ₁	AJ	AJ ₁	AK	AK ₁
11	.188	3.72	2.22	6.10	4.41	3.74	6.30	6.50	6.50	.156	.188	3.94	5.43	.41	.41	.35	M6	.59	.188	—	5.88	5.88	4.50	4.50
12	.188	4.69	2.56	6.50	4.13	4.33	7.32	6.50	6.50	.156	.188	4.25	6.02	.41	.41	.35	M8	.59	—	.219	5.88	5.88	4.50	4.50
13	.188	5.22	2.90	9.06	5.51	5.51	9.57	6.50	6.50	.156	.188	5.31	7.40	.41	.41	.47	M8	.91	—	.188	5.88	5.88	4.50	4.50
14	.250	6.06	3.24	9.25	6.30	5.91	10.31	9.00	9.00	.250	.219	5.71	7.80	.52	.52	.47	M10	.91	.094	—	7.25	7.25	8.50	8.50
15	.250	6.49	3.70	12.01	8.27	7.09	11.81	9.00	9.00	.250	.219	6.69	8.86	.52	.52	.47	M10	.91	.219	—	7.25	7.25	8.50	8.50
16	.312	8.59	4.93	14.17	9.45	8.66	14.37	10.00	10.00	.250	.219	7.60	10.31	.52	.52	.57	M12	1.34	.219	—	7.25	7.25	8.50	8.50
16B	—	8.59	4.93	14.17	9.45	8.66	14.37	10.00	—	.250	—	9.06	10.31	.52	—	.57	M12	1.34	—	—	7.25	—	8.50	—
17	—	9.31	5.08	16.93	11.42	11.02	17.72	11.25	—	.250	—	8.94	11.50	.52	—	.71	M14	1.57	—	—	9.00	—	10.50	—
17B	—	9.31	5.08	16.93	11.42	11.02	17.72	11.25	—	2.50	—	9.06	11.50	.52	—	.71	M14	1.57	—	—	9.00	—	10.50	—

Note: Metric input and output shafts and IEC standard flanges are available upon request.

Type 21 and 22 Dimensions (in)

HSV Size	A ²	A ³	A ₄	A ₅	C ₁
11	19.27	17.52	10.49	8.74	13.18
12	23.19	21.07	12.96	10.84	14.70
13	24.64	22.52	15.51	13.39	17.45
14	27.58	24.70	16.46	13.58	19.25
15	34.45	31.57	21.34	18.46	23.25
16	CF	38.20	27.70	24.32	25.61
16B	—	—	35.10	31.72	33.96
17	—	—	32.10	27.48	36.24
17B	—	—	38.64	34.02	36.47

Type 30

Variator-reducer combination

Type 31

Variator-reducer with C-flange input kit

Type 32

Variator-reducer with top-mount kit

Type 41

Motor-Variator-Reducer combination with C-flange motor and reducer (In-line configuration)

Type 42

Motor-Variator-Reducer combination with top-mounted motor

The dimensions for Type Nos. 30 to 42 can be found by adding the dimensions of the types 10, 11, 21 and 22 to the gear reducer dimensions shown on page E1—9.

DIMENSIONS HSV-A (IN.)

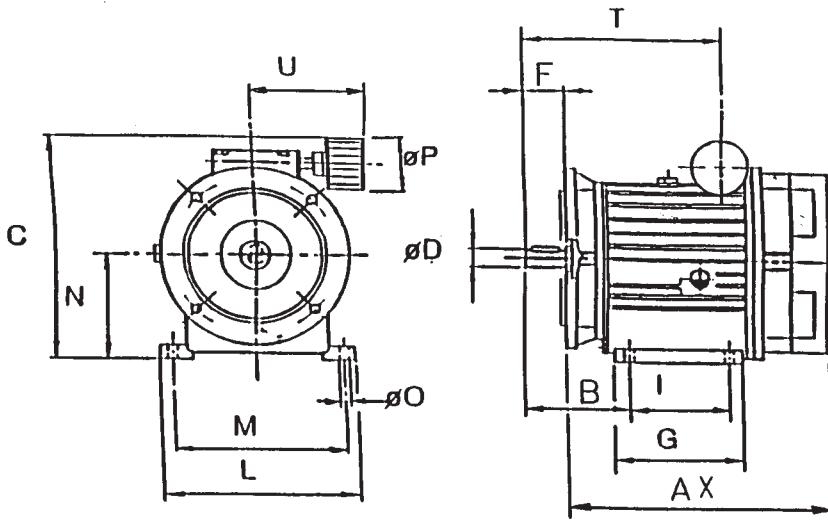

TYPE 11
(C in – C out)
(Std. configuration)

HSV Model	B	C	D	F	G	I	L	M	N	O	P	T	U	AX	NEMA Frame	Weight lbs.
A2	3.48	7.4	0.625	1.75	3.74	2.68	6.89	5.7	3.27	0.35	1.97	6.24	4.76	7.4	56	20
A4	4.09	8.54	0.875	2.12	4.33	3.15	7.83	6.69	4.02	0.35	1.97	7.12	4.76	8.13	140	27
A8	4.68	9.21	0.875	2.12	5.12	3.54	9.33	8.19	4.13	0.47	1.97	8.14	4.76	12.44	140	45
A10	5.88	11.08	1.125	2.875	5.71	3.94	10.63	9.45	5.12	0.47	1.97	9.67	4.76	13.3	180	75
A12	5.88	11.08	1.125	2.875	5.71	3.94	10.63	9.45	5.12	0.47	1.97	9.67	4.76	13.3	180	75

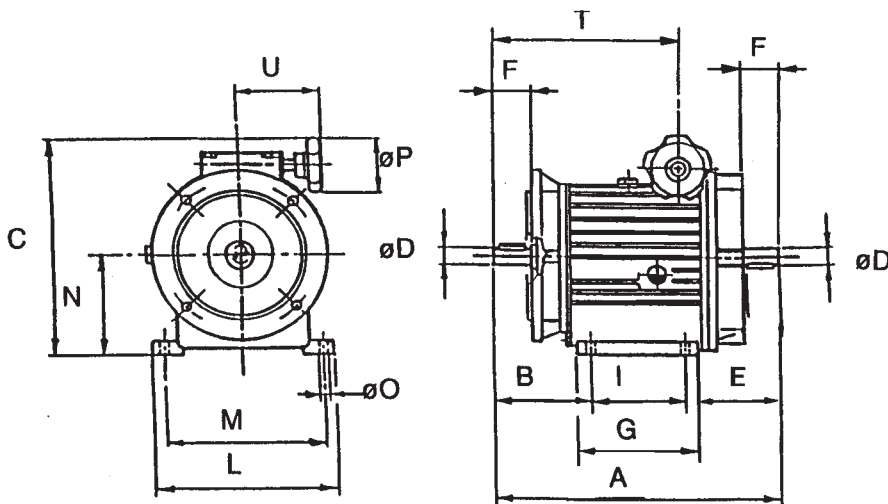

TYPE 10
(Shaft in – Shaft out)

HSV Model	A	B	C	D	F	G	I	L	M	N	O	P	T	U	E
A2	9.95	3.48	7.40	.625	1.75	3.74	2.68	6.89	5.71	3.27	0.35	1.57	8.24	4.76	3.79
A4	11.5	4.09	8.54	.875	2.12	4.33	3.15	7.83	6.69	4.02	0.35	1.57	7.12	4.76	4.26
A8	12.99	4.68	9.21	.875	2.12	5.12	3.54	9.33	8.19	4.13	0.47	1.57	8.14	4.76	4.77
A10	19.32	5.88	11.08	1.125	2.875	5.71	3.94	10.63	9.45	5.12	0.47	1.97	9.67	4.76	9.5
A12	19.32	5.88	11.08	1.125	2.875	5.71	3.94	10.63	9.45	5.12	0.47	1.97	9.67	4.76	9.5

DIMENSIONS GEAR REDUCERS



Single Reduction DC11, 21, 31, 41, 51

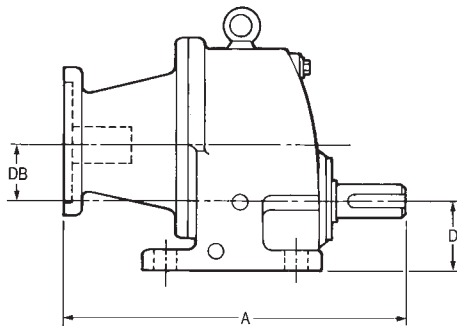

Double Reduction DC02, 12, 22, 32, 42, 52, 62, 72, 82, 92

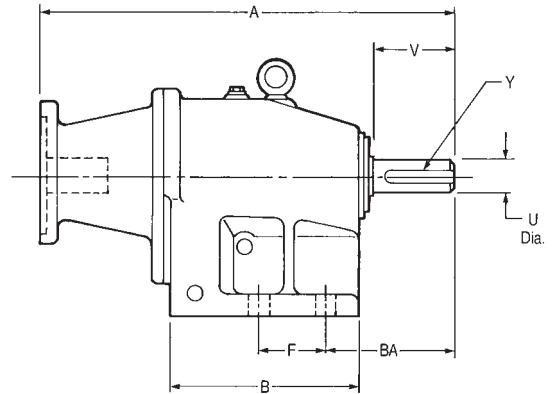

Triple Reduction DC23, 33, 43, 53, 63, 73, 83, 93, 103

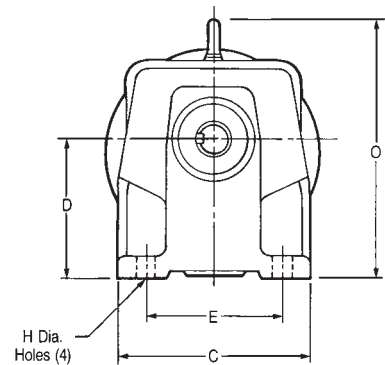
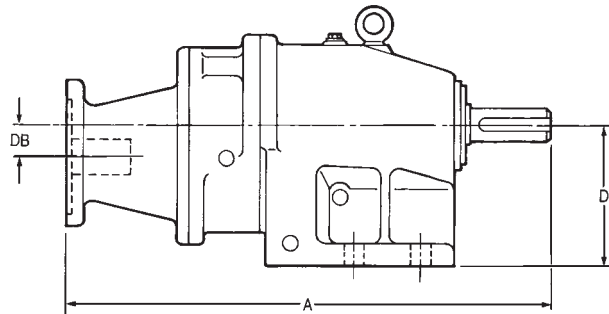

Reducers Dimensions (inches)

Gearbox Size	A*	NEMA Frame Size	B	BA	C	D	DB	E	F	H	O	U	V	Y
DC 02	11.5	—	5.28	1.97	5.12	3.39	—	4.33	2.36	0.35	6.7	0.750	1.50	0.188
DC 11	9.3	—	3.94	2.12	5.31	2.20	1.97	4.13	3.15	0.35	7.4	0.750	1.50	0.188
DC 12	12.7	—	5.47	3.22	5.31	4.02	—	4.13	2.44	0.35	7.3	1.000	2.13	0.250
DC 21	10.8 12.8	56C/145TC 182TC/184TC	5.51	2.75	7.28	2.80	2.40	6.30	4.53	0.43	9.7	1.000	2.13	0.250
DC 22	14.4 15.3	56C/145TC 182TC/184TC	6.89	3.30	7.28	4.92	—	6.30	3.15	0.43	8.8	1.250	2.75	0.250
DC 31	14.3 16.5	182TC/215TC 56C/145TC	6.50	3.50	8.27	3.35	2.99	6.89	5.31	0.51	12.13	1.250	2.75	0.250
DC 32	18.5* 13.1	182TC/215TC 56C/145TC	8.43	3.88	8.27	6.10	—	6.89	4.72	0.51	11.50	1.625	3.25	0.375
DC 41	16.7 18.1	182TC/215TC 56C/145TC	8.07	3.94	8.46	3.94	3.39	6.89	6.50	0.51	14.33	1.375	3.00	0.313
DC 42	21.7*	182TC/215TC	9.41	5.07	8.46	6.89	—	6.89	4.72	0.51	12.87	1.875	3.50	0.500
DC 51	17.3	—	8.66	4.19	10.24	4.41	4.17	8.46	7.09	0.71	15.94	1.625	3.25	0.375
DC 52	23.7*	—	11.14	5.18	10.24	8.35	—	8.66	5.91	0.71	15.08	2.250	4.00	0.500
DC 62	26.6 28.7	182TC/215TC 284TC/286TC	13.58	6.34	12.99	9.84	—	10.24	11.61	0.87	18.91	2.500	5.00	0.625
DC 72	28.1 30.3	182TC/215TC 284TC/286TC	15.16	7.04	15.75	11.02	—	12.80	12.90	1.02	21.65	3.000	5.50	0.750

* Overall length on 182TC/184TC flange size may be shorter.

HSV-A

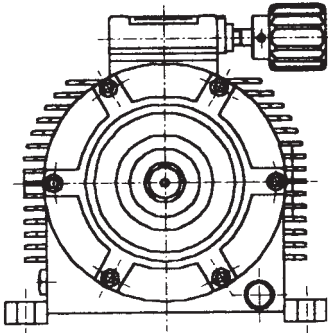

Code 00
Standard Handwheel Control

This is the standard control supplied with the HSV. It provides precise speed control in both directions and ease of operation. The number of turns from maximum reverse to forward and the operating torque is shown in the table below.

HSV

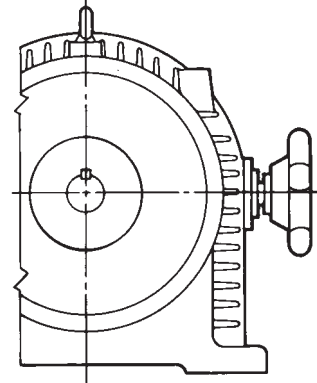

Code 01
Right Angle Handwheel Control

This control incorporates a bevel gear set and operates identically to the Code 00. The handwheel can be rotated to several positions so that it faces down, horizontal or some other convenient angle.

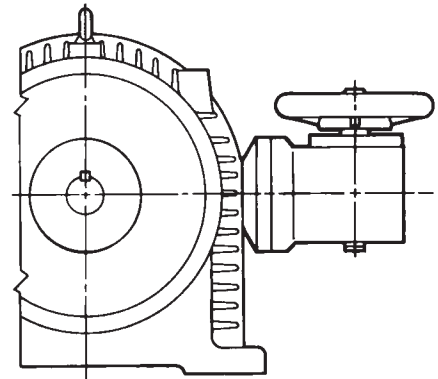

Code 02
Lever Control

This lever control operates over approximately 90 degrees from maximum reverse to forward. It has a friction clutch to adjust the amount of force required to stroke it and will stay in place when set. The control can be adjusted to locate this zero position at different angular locations. There is about 5 degrees of deadband in the control on either side of the center zero position.

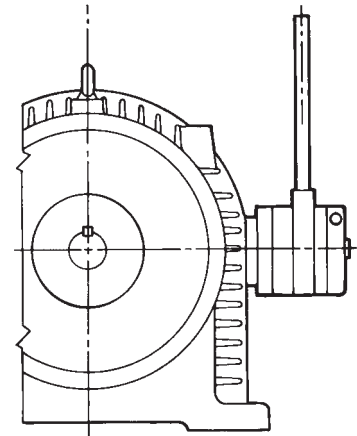

HSV-A

NOT AVAILABLE

Code 03

Heavy Duty Lever Control

This operates in the same manner as the Code 02 but is recommended for more frequent use. It is also available in a flanged version (Code 03F) to mount some other device such as a chain sprocket for example.

HSV

NOT PICTURED

Code 09

Handwheel Control with Flexible Shaft

NOT AVAILABLE

This control incorporates 6 feet of flexible shaft for remote mounting the handwheel to a bracket or panel. Available on sizes 11 through 15 only.

NOT PICTURED

Code 12

Clevis Control

NOT AVAILABLE

This high force control is directly connected to the variator pump eccentric ring. Stroking the clevis in and out changes the speed. The Zeroing Device (option 6) can be added to assure a return to zero speed when control forces are released. Force requirements and maximum clevis travel are shown in the table below.

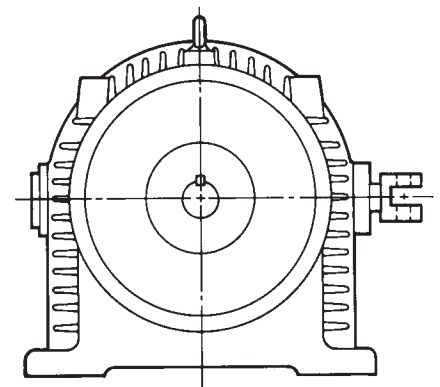

ELECTRONIC REMOTE CONTROLS (ERC)

HSV-A

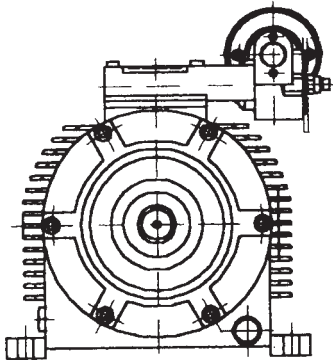

Code 20 **ERC (Fast)**

The ERC's consist of a small motor driving a worm gear through a slip clutch to control the position of the eccentric ring in the variator. The slip clutch allows for a manual handwheel override and protects the small electric motor from stalling if over-controlled. The response time from zero to maximum speed is 14 seconds. The standard motor is a permanent split capacitor type. The position of the motor can be rotated around the axis of the handwheel. See notes below.

Code 22 **ERC (Slower)**

This control operates more slowly than the Code 20 requiring 50 sec. to go from zero to maximum speed. All other features are the same.

Code 23 **ERC (Slowest)**

This control operates more slowly than the Code 20 requiring 125 sec. to go from zero to maximum speed. All other features are the same.

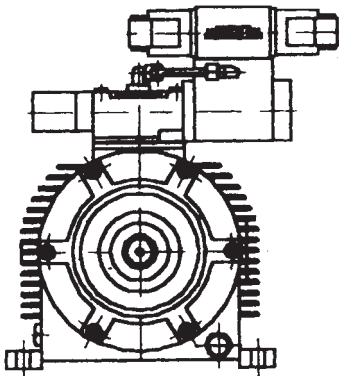

Code 31 **PLC / Hydraulic**

This control interfaces with a digital electronics card on the customers machine (PLC or PC). This control provides for infinite speed control and bi-directional operation with feed back. The solenoid valve may also be pulsed to provide proportional speed control.

HSV

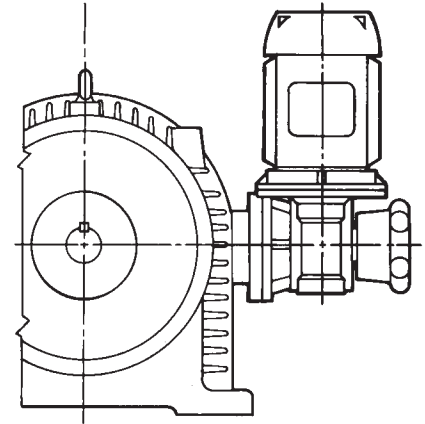

Code 22 **ERC (Slower)**

This control operates more slowly than the Code 20 requiring 50 sec. to go from zero to maximum speed. All other features are the same.

Code 23 **ERC (Slowest)**

This control operates more slowly than the Code 20 requiring 125 sec. to go from zero to maximum speed. All other features are the same.

NOT AVAILABLE

HSV-A

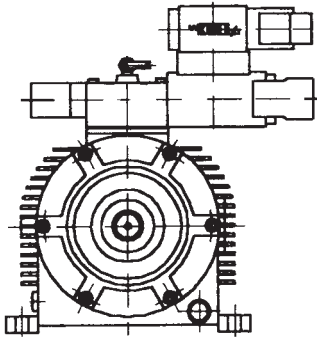

Code 37 **Electronic Control**

This Electro-Hydraulic - Electronic proportional control provides a continuous speed adjustment by means of closed loop regulation. It will ensure speed stability even when there is a large variation in load. The control accepts a continuously changing reference signal and can provide adjustable acceleration and deceleration ramps. Speed regulation can be obtained using potentiometers or analog signals. The control uses an Electronic card with speed feedback sensor and proportional solenoid valve. Direction of rotation must be specified.

HSV

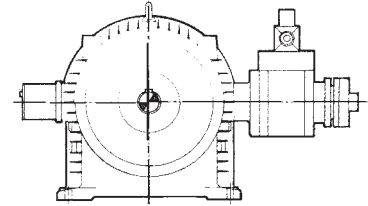

Code 38 **Electronic Control**

Same as Code 37 but includes a second solenoid valve to allow for mechanical zeroing of input shaft

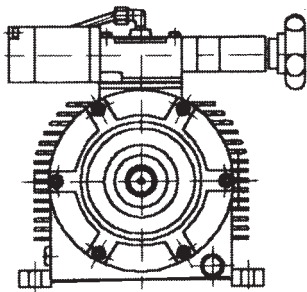

Code 46 **Gradual Start Manual**

This control provides handwheel control but includes adjustable start times from 2 to 20 seconds. It is recommended for high inertia starting. Direction of rotation must be specified. For bi-directional operation, a Code D reversible charge pump is required.

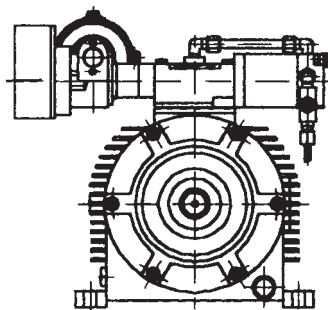
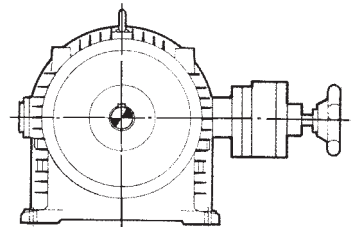

Code 49 **Gradual Start ERC**

Same as Code 46 except uses an electric gear motor control rather than the handwheel.

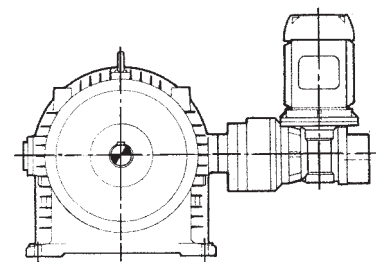

PNEUMATIC PROPORTIONAL CONTROLS

HSV-A

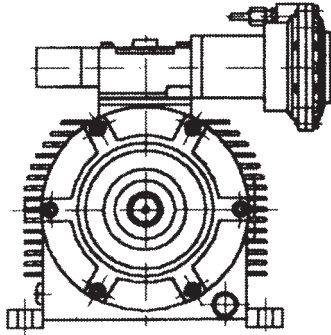

Code 52

Hydropneumatic Proportional Control (3-15 psi)

Instrument air pressure at 3-15 psi is used to stroke this control from zero to the maximum speed. For CW rotation the control is mounted on the left; for CCW rotation the control is mounted on the right. Ideal for explosion-proof environments this control is sensitive, rugged and reliable. Simple in design, it has only one diaphragm and two springs.

Note: Control for one direction only. Specify rotation direction.

HSV

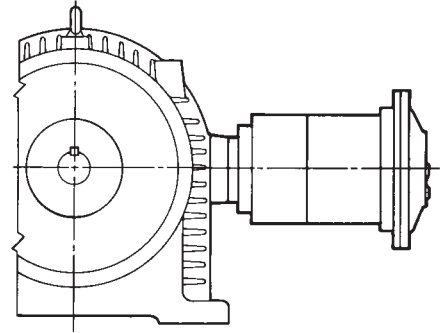

Code 53

Hydropneumatic Proportional Control (15-45 psi)

This control is identical in construction to the Code 52 except it has a smaller diaphragm to accept higher air pressures. In addition, it has a small needle valve in the hydraulic supply line to meter oil into the control thereby providing an adjustable acceleration time (ramping). Rotation and mounting considerations are the same as the Code 52.

Note: Control for one direction only. Specify rotation direction.

NOT AVAILABLE

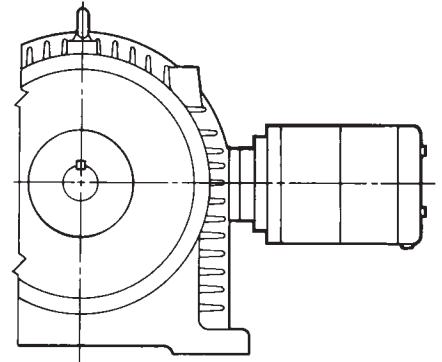

ELECTROHYDRAULIC REMOTE CONTROLS

All of the electrohydraulic controls consist of a double-acting cylinder controlled by a 4-way valve. Powered by the charge pump, the controls are fully reversible. Manually preset speeds and liner (jerk-free) accelerations are the important features of these controls.

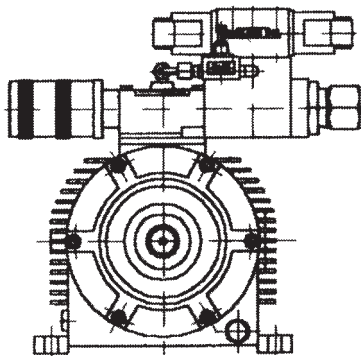

Code 65

Electrohydraulic Control with two preset speeds and zeroing device

This allows the HSV to operate at two different speeds which are preset by ring nuts. A small flow control valve permits controlled acceleration between the two speeds. Releasing both solenoids on the directional valve brings the control to zero speed without shutting off the input motor.

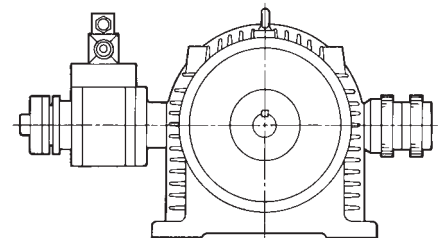

ELECTROHYDRAULIC REMOTE CONTROLS



HSV-A

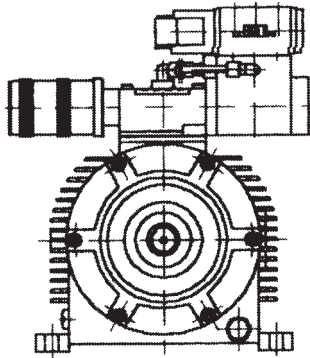

NOT AVAILABLE

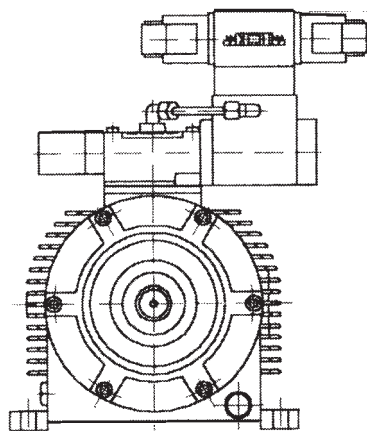

NOT AVAILABLE

Code 66

Electrohydraulic Control with two preset speeds only

Identical in function to the Code 65, this control operates only at one or the other of two preset speeds. Zeroing of the control is assured only if one of the ring nuts is set at zero speed.

Code 67

Electrohydraulic remote control with zeroing device

This control incorporates a cylinder locking valve and two flow controls that meter oil out of the control. This allows the control to lock into any speed while accelerating or decelerating (linear ramping). Furthermore, the two flow controls allow independent control of acceleration and deceleration ramps. When the HSV is shut off the control automatically moves to the zero speed position.

Code 67

Remote Electrohydraulic Control

This control adjust the variator speed through push buttons and gives the same control as code 20 (Remote Electric Control). This control is recommended when rapid acceleration and deceleration is required or when there are frequent speed changes. The control also contains a device to adjust the acceleration and deceleration ramp.

Code 68

Electrohydraulic remote control with electrical auxiliary zeroing device

A solenoid valve (19A) is used to cut flow to the control thereby allowing it to stroke to zero speed without having to shut off the driving motor. In all other aspects the control is identical to the Code 67. Solenoid 19A must be energized for the control to operate. The auxiliary zeroing feature is not intended to be used as an emergency shutdown, it merely overrides any preset ramps.

HSV

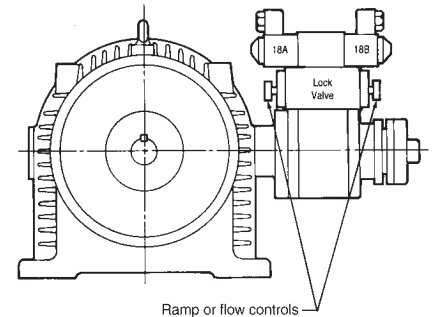
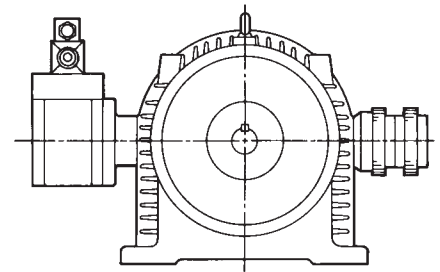

NOT AVAILABLE

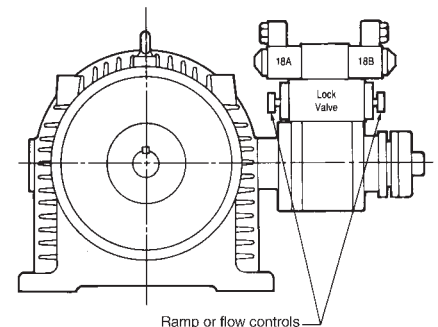

HSV-A

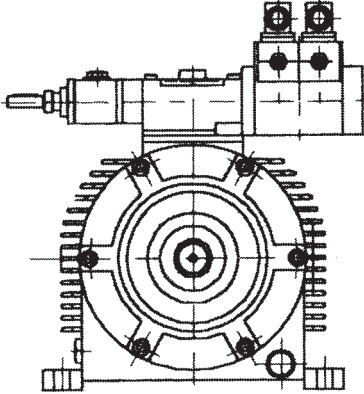

Code 71

Synchronized Control

The control synchronizes two speeds (primary and secondary). Power factor correction is substituted by this control. The Synchronizer Control is mainly used on Packaging Machines (Flow Pack Systems).

The control is used to keep the label and bags in a central position compared to the bag length. The control has two input controls: one by handwheel setting the feed or the package length, the second utilizes a piloted impulse to a solenoid valve from proximity switches or from a photo-electric cell. This latter signal allows the handwheel setting to be increased or decreased to ensure the label position central on the bag.

HSV

NOT AVAILABLE

Code 0013

Device For Automatic Winders

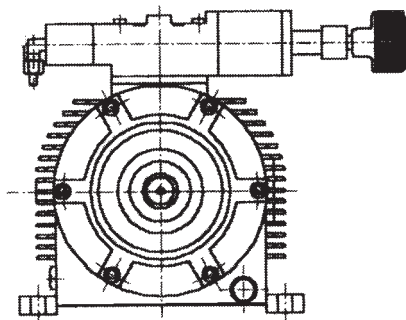

It permits controlling output shaft variable speed of the variator according to the resistance torque. Speed is automatically decreased according to the increasing diameter of the reel and corresponding peripheral speed. This permits winding at a controlled tension with a 1:6 ratio of minimum and maximum diameter- In order to get lower or higher tension values, it is necessary to make manual regulations with handwheel.

NOT AVAILABLE

When placing orders please state direction of rotation of output shaft.

The Hydrostatic Speed Variator is available with a wide variety of accessories and options that can extend and improve the capabilities of the standard control mechanisms as well as monitor and control system loading.

HSV-A

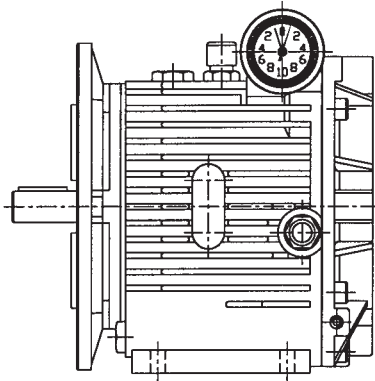

Code 0

Handwheel with Indicator Dial HSV & HSV-A

The gravity type indicator has a scale which reads the number of handwheel turns and fractions thereof. It allows an operator to set the speed and then return to it when needed. It does not provide a direct speed readout. The hands on the dial operate like the hands of a clock.

HSV



Code 3

Device for Automatic Winders (Pressure Compensator)

HSV Only

This device monitors torque load on the HSV by sensing system pressure. It destrokes or slows down the unit in response to increasing torque thereby eliminating the need for a dancing roller on a windup machine. Other applications involving load sensing are possible. Contact the factory for further details.

Code 4

Adjustable Torque-Limiting (Relief) Valves HSV Only

This inexpensive device can decrease the relief valve setting to limit torque in torque-sensitive applications. Starting torque capability is likewise reduced.

Code 6

Zeroing Device HSV Only

This device will spring center the eccentric ring of the HSV to bring the drive to zero speed. It can be used in conjunction with control codes 02,03 and 12 for a positive control to zero.

Code 8

Tachometer Package HSV & HSV-A

A two-pole pickup in the HSV generates a small alternating current whose voltage is proportional to the RPM. The pickup and wheel are contained inside the HSV. The position of the pickup can be rotated. The meter can be calibrated to almost any scale, for example feet per minute or gallons per minute, etc. A digital tachometer is available at additional cost.

Code 9

Limit Switch Boxes for Presetting Speeds

HSV & HSV-A

The switch boxes mount on the HSV opposite the control mechanism and are used to set speeds in conjunction with control codes 20, 22, 67 and 68.

Code 9 (2) Sets 2 speeds

Code 9 (3) Sets 3 speeds

Code 9 (6) Sets 4 speeds and zero speed

Code A – HSV only

Separate Charge Pump

This option gives design flexibility in two areas. First it allows the HSV to accept input speeds below 900 RPM. Secondly, it allows for reversal of the input shaft rotation to get bi-directional performance out of uni-directional controls (Codes 52 and 53). The external pump is also supplied with small driving motor.

Code B – HSV only

Bypass Valve

The bypass valve is connected to both sides of the hydrostatic closed loop. When open it allows flow from one side to the other bypassing the hydraulic motor. It is intended for applications requiring the HSV output shaft to freewheel when shut off. It can also be used when a brake is applied to the output shaft. Pressure drop through the valve when the HSV is stroked and running will result in rotation of the output shaft.

Code C – HSV & HSV-A

Vertical Mount Kit

The HSV can be mounted with shafts vertical or with feet on a sidewall. To do so requires the installation of a vertical mount kit which is a small duct to supply the charge pump inlet with oil. Not available on the model 16B or 17B.

Code D – HSV & HSV-A

Reversible Charge Pump for HSV Sizes 11, 12, 13, 14, 15, A2, A4, A8, A10, A12

This option allows for reversal of the input electric motor, thereby gaining two advantages: Bi-directional performance from uni-directional controls codes (52 and 53), and doubling the number of preset speeds for the controls and options that offer them.

Code F – HSV only

Flow Controls for codes 65 and 66

These allow independent acceleration and deceleration ramps to be set for the two controls.

Code G – HSV & HSV-A

Potentiometer Feedback

It is a device supplied on request with control code 20-22-23. The code G is a linear potentiometer that reads the exact relationship of the position of the variator control to the speed of the variator. Any speed change causes a movement of the potentiometer and hence a change of signal. The potentiometer gives a feedback to the electronic card (RCF) or other device allowing a continuous control of the unit speed.

Code M – HSV & HSV-A

Pressure Tap

System pressure which is proportional to torque can be monitored with the pressure tap. A gauge can be used to monitor torque or a pressure switch can be tripped to limit torque and protect the system. A single tap to read one side of the hydrostatic loop or a double tap to read both sides is available. A pressure gauge or a pressure activated switch is available.

Code N – HSV & HSV-A

Thermo Switch

This option provides a switch if the HSV unit exceeds a predetermined temperature.

Code P – HSV & HSV-A

Preheat Kit

This consists of 1 or 2 immersion heaters and a thermostwitch to preheat the oil for extremely cold environments. They are rated for 115 VAC, 60 Hz.

Code Q – HSV only

Compensated Flow Control

This pressure and temperature compensated flow control provides more uniformity of control response under varying temperature conditions. It can be incorporated into any hydraulic control powered by the charge pump.

Code R – HSV & HSV-A

Oil Cooler Package

This option consists of a cooler valve and a radiator with fan motor to cool the oil in high ambient temperature applications. Excess charge pump flow is brought outside the HSV with the cooler valve. It is then sent to the air-oil heat exchanger and returned to the case of the drive. Other types of heat exchangers may be used in conjunction with the valve.

Code S – HSV & HSV-A

Electronic Adjuster

This device is exclusively coupled with electric controls (code 20-22-23-31 and 67).

The card allows the proportional adjustment of the control dependent upon the input preset signal. The RCF adjuster operated in a closed loop using a voltage signal from a potentiometer (code G) which continually monitors the situation of the variator (for controls 20-22-23). The RCF-FT adjuster can have a feedback also from Code 8 (directly speed feedback).

Code W – HSV only

Remote Speedset Device

Used in conjunction with control Codes 65 and 66, this electrohydraulic device can be remotely set to two equal speeds in opposite directions of rotation.

Code Z – HSV & HSV-A

Miscellaneous Options

- Epoxy Paint
- Synthetic Oil
- Stainless Steel Shafts and Hardware
- Special Breather

The breather option is recommended for dusty, dirty and heavy washdown environments. A pressure activated, sintered metal breather, excludes contaminants for the interior of the HSV case.

Note: Accessory Codes 3 and 4 and Option Codes B and M are mutually exclusive. Only one may be mounted to a variator.

Altra Industrial Motion

Warner Electric

Electromagnetic Clutches and Brakes - USA

South Beloit, IL
815-389-3771

For application assistance:
1-800-825-9050

Electromagnetic Clutches and Brakes - Europe

St Barthelemy d'Anjou, France
+33 (0)2 41 21 24 24

For sales office:
+33 (0)2 41 21 24 76

Precision Electric Coils and Electromagnetic Clutches and Brakes - USA

Columbia City, IN
260-244-6183

Inertia Dynamics

Spring Set Brakes; Power On and Wrap Spring Clutch/Brakes

Torrington, CT
860-482-4444

Matrix International

Electromagnetic Clutches and Brakes, Pressure Operated Clutches and Brakes

Brechin, Scotland
+44 (0) 1356 602000

U.S.
815-389-3771

Warner Linear

Linear Actuators and Guideways - USA

Belvidere, IL
815-547-1106

For application assistance:
1-800-825-9050

TB Wood's

V-Belt Drives, Synchronous Drives, Flexible Couplings, Variable Frequency AC Drives

Chambersburg, PA
717-264-7161

For assistance:
1-888-829-6637
Press #5 – Customer Service
Press #7 – Mechanical Applications
Press #8 – Electronic Applications

Wichita Clutch and Industrial Clutch

Pneumatic and Oil Immersed Clutches and Brakes - USA

Wichita Falls, TX
940-723-3400

Pneumatic Clutches and Brakes - Europe

Bedford, England
+44 (0)1234 350311

Twiflex Limited

Caliper Brakes and Thrusters

Twickenham, England
+44 (0) 20 8894 1161

Formsprag Clutch

Overrunning Clutches and Holdbacks

Warren, MI
586-758-5000

For application assistance:
1-800-927-3262

Marland Clutch

Roller Ramp and Sprag Type Overrunning Clutches and Backstops

Burr Ridge, IL
630-455-1752

Stieber Clutch

Overrunning Clutches and Holdbacks

Heidelberg, Germany
+49 (0)6221 30 47 0

Boston Gear

Enclosed and Open Gearing, Electrical and Mechanical P.T. Components

Charlotte, NC
704-688-7300

For customer service:
1-800-825-6544

For application assistance:
1-800-816-5608

Huco Dynatork

Precision Couplings and Air Motors

Hertford, England
+44 (0) 1992 501900

U.S.
800-825-6544

Ameridrives Couplings

Gear Couplings, Mill Spindles, Universal Joints

Erie, PA
814-480-5000

Bibby Transmissions

Disc, Gear, Grid Couplings, Overload Clutches

Dewsbury, England
+44 (0) 1924 460801

Nuttall Gear and Delroyd Worm Gear

Worm Gear and Helical Speed Reducers

Niagara Falls, NY
716-298-4100

Saftek Friction

Non-asbestos Brake and Clutch Materials

Telford, England
+44 (0) 1952 581122

Altra Industrial Motion - Asia Pacific and Africa

China	852 2615 9313
Taiwan	886 2 2577 8156
Singapore	65 487 4464
Thailand	66 2 322 5527
Australia	612 9894 0133
S. Africa	27 11 918 4270



An Altra Industrial Motion Company

TB Wood's Incorporated

440 North Fifth Avenue • Chambersburg, PA 17201
717-264-7161 • Fax: 717-264-5420
www.tbwoods.com